

MMH Scan™

Analysis + Definition of Barriers to Missing Middle Housing

Prepared for:
City of Columbia

**December 06,
2023**

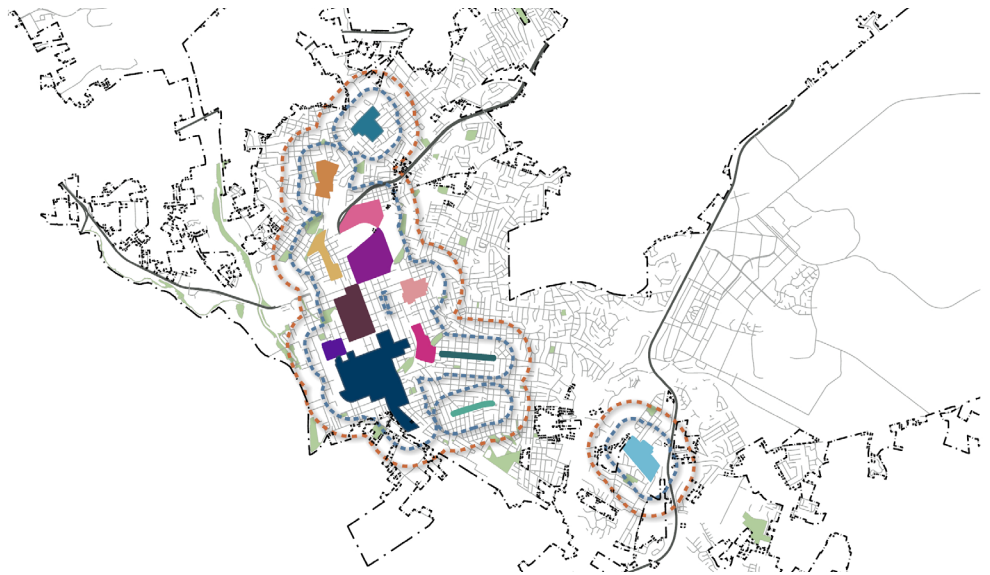

Prepared For:

Central Carolina REALTORS® Association

1901 Main Street, STE 175

Columbia, SC 29201

803.771.8852

www.ccrasc.com

and the

City of Columbia

Planning and Development Services

1136 Washington Street

Columbia, SC 29201

www.ColumbiaSC.gov

Prepared By:

Opticos Design, Inc.

2100 Milvia Street; Suite 125

Berkeley, California 94704

510.558.6957

Missing Middle Housing term created by Daniel Parolek/Image © Opticos Design, Inc./For more info visit www.missingmiddlehousing.com

What's Inside?

MMH Scan™ Analysis + Definition of Barriers to Missing Middle Housing

Chapter 1	Purpose + Objectives	5
	What This Study Is About	6
	Overview of Columbia's Population + Housing	8
	Why Missing Middle Housing(MMH) Is Important in The Future of Communities	10
Chapter 2	About Missing Middle Housing	13
	What Is Missing Middle Housing (MMH)?	14
	What Defines a Missing Middle Building Type?	20
	Frontage Types for Missing Middle Housing	34
	Missing Middle Housing in the City of Columbia	36
	Walkable Centers in Columbia	38
	Missing Middle Housing-Ready Neighborhoods	42
Chapter 3	Analysis of Barriers	49
	Summary of Comprehensive Plan and Other Policy Plans	50
	Summary of Zoning Districts, Overlays, and Zoning Standards	56
	Summary of Barriers	60
	Allowed Density	62
	Minimum Lot Area/Width	64
	Next Steps	66

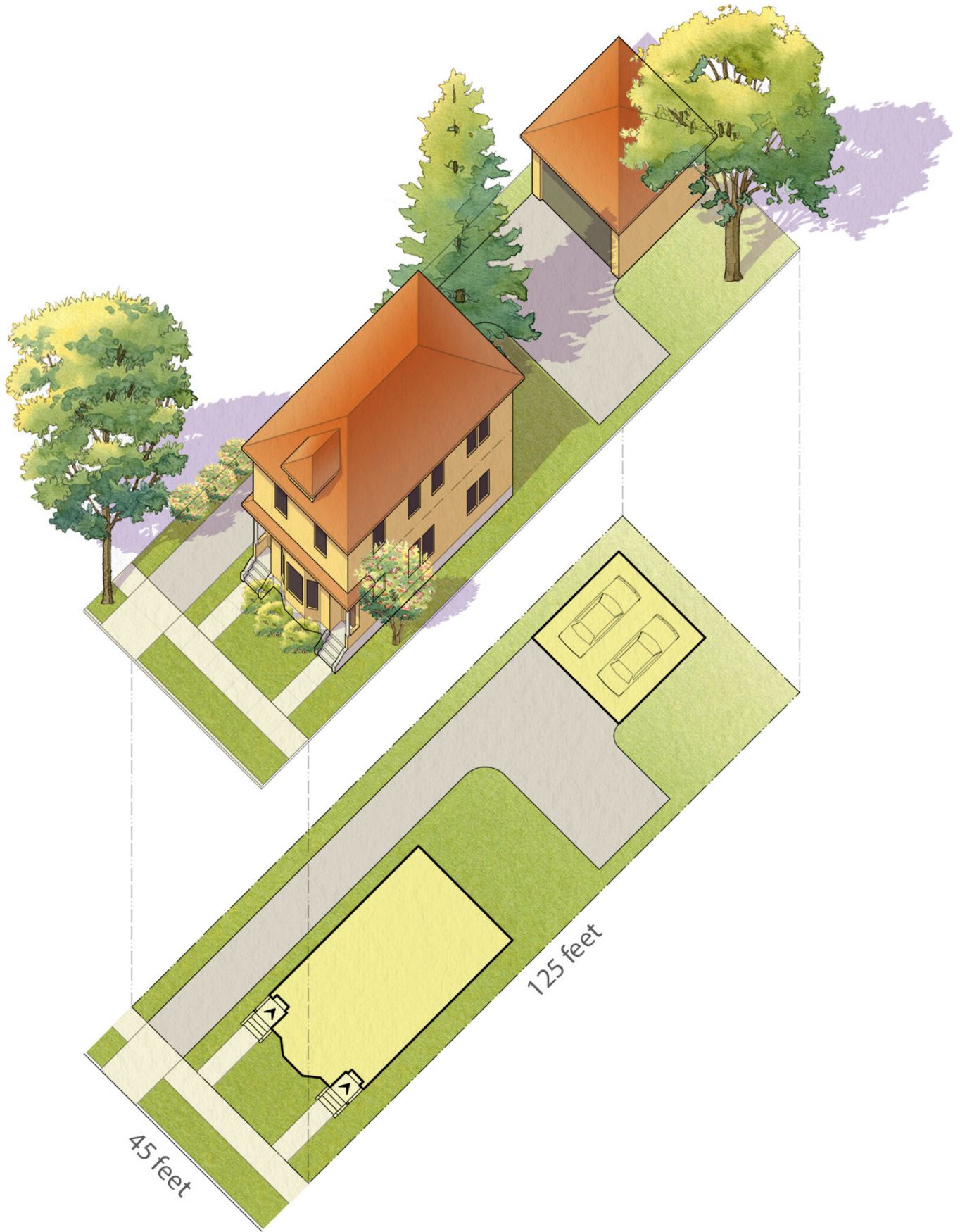

Purpose + Objectives



In this chapter

What This Study Is About	6
Overview of Columbia's Population + Housing	8
Why Missing Middle Housing (MMH) Is Important in The Future of Communities	10

1.1

What This Study Is About

The City of Columbia is working to ensure that growth and reinvestment result in the variety of housing choice and affordability that are key for its future needs.

Source

¹Dr. Arthur C. Nelson "Missing Middle: Demand and Benefits", Utah ULI Conference, October 21, 2014

²U.S. Census Bureau

The Need for More Housing Choice

In the United States, 90 percent of available housing is located in conventional single-family neighborhoods. This land use pattern, among other factors, has contributed to a housing shortage of approximately 35 million housing units.¹ At the same time, real estate trends indicate increasing demand nationwide for greater housing choices in walkable environments, with convenient access to amenities and services, and reduced dependence on driving for daily needs. But the choices offered by most housing markets continue to be either single-unit houses or large apartment projects.

The City of Columbia, from 2010-2021, gained 5,828 units. The largest increase has been in single-unit detached, single-unit attached, and large apartments (over twenty units). The amount of small multi-unit buildings (two to four units) has decreased during this time.²

The Need for Regulatory Change

Too often, the types and size of new dwellings that the market wants are not allowed by local policy or zoning regulations. This means that innovative developments need to go through complex and uncertain review processes when trying to respond to the shifting market. Regulatory change is needed to

Figure 1.1 An example of a Townhouse MMH type in Columbia



make new investment predictable and simple.

Missing Middle Housing (MMH) is intended to be part of low-rise residential neighborhoods, which are typically zoned as “single-family residential” in conventional zoning. In this analysis “single-family” is also referred to as “single-unit.” However, because MMH contains multiple units, it is, by definition, not allowed in single-unit zoning districts.

Most multi-family zoning districts in conventional codes allow much bigger buildings (both taller and wider) and also typically encourage lot aggregation and large suburban “garden apartment” buildings. The environments created by these zoning districts are not what is intended by Missing Middle Housing.

Focus of the Study

This study analyzed existing and potential walkable centers within the City with an objective to identify areas suitable for MMH. This was followed by the regulatory analysis of four zoning districts selected by the City of Columbia staff, to study how these zones could contribute to generating MMH.

The zoning districts selected were RM-1, RM-2, NAC, and MU-1, and these were selected for two key reasons: the extent to which they occur near existing and potential walkable centers, and because the allowed size and scale of buildings in these zones aligns with the house-scale nature of typical MMH types.



Figure 1.2 An example of a duplex MMH type.

1.2

Overview of Columbia's Population + Housing

A starting point to understanding Columbia's housing needs is to review how its population is projected to change over the coming decades.

Population Projections

Columbia is the county seat for Richland County and had a population of about 137,000 in 2022, with approximately 50,000 households. According to the Central Midlands Region Population Projection Report, by 2050, Richland County is projected to become home to an additional 250,000 residents. The county is projected to grow at an annual rate of 1.8 percent. This report estimates

the population of Downtown Columbia will be 55,000 residents by 2050.

According to the 2021 South Carolina Housing Needs Assessment, Richland County is identified as a county with high demand for new construction: 173,043 housing units are needed across the entire county. To put this number in perspective, between the years of 2010-2021, the City of Columbia produced only 5,828 units.

Columbia's Population Characteristics¹

Total Population	137,276
Average Household Size	2.19
Homeowners	46.1%
Renters	53.9%
Vacant Housing Units	14.5%
Median Household Income	\$48,791
Median Home Value	\$193,100
Median Monthly Rent	\$1,007
Total Amount of Land	88,198 acres
Amount of Land with Relevant Zoning Standards ²	28,370 acres
Amount of Land Zoned for Multi-Family Housing	9,406 acres (33.2% ²)

¹U.S. Census Bureau, American Community Survey (ACS)

²Based on all parcels with assigned zoning, excluding rights-of-way, Planned Development districts, and Fort Jackson.







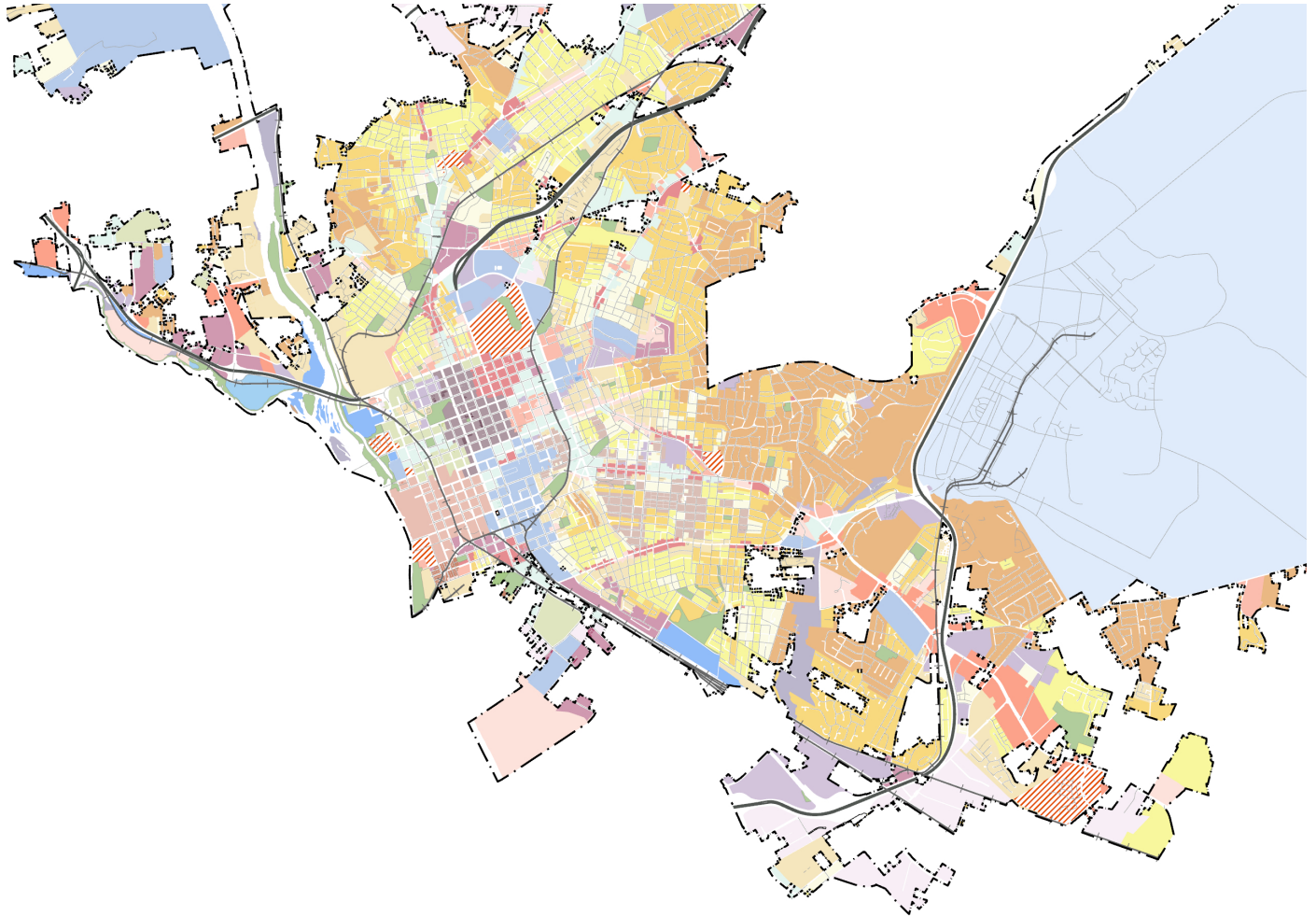

















Housing Types (Existing)¹

	Total	%
Single-Unit, Detached	30,077	51.1
Single-Unit, Attached	2,906	4.9
Duplexes	2,916	5.0
3 - 4 Units	3,486	5.9
5 - 9 Units	4,789	8.1
10 - 19 units	9,832	7.3
20+ Units	9,832	16.7
Mobile Homes	590	1.0
Other	16	0.0
Total:	48,905	

Figure 1.3 Zoning Districts



Zoning Districts

 CAC	 INS-FJ	 LL-R	 RAC	 RSF-1
 DAC	 INS-GEN	 MC	 RD	 RSF-2
 EC	 INS-T/U	 MU-1	 RD-MV	 RSF-3
 GC	 INS-ZOO	 MU-2	 RM-1	 T/C
 HI	 LI	 O-I	 RM-2	 PD

1.3

Why Missing Middle Housing (MMH) Is Important in The Future of Communities

Eight key national trends point to Missing Middle Housing as an essential strategy for communities to spur reinvestment and housing production.

Sources

¹National Association of Realtors

²American Planning Association

Cities Are Prioritizing Walkability for Their Triple-bottom-line Benefits

- The improved physical and mental health of residents
- Environmental stewardship
- Economic benefits

Walkable Living in Demand

- There is a 20-35 percent gap between the demand and supply of walkable urban living choices, created by the fact that on the supply side, essentially two housing products are being provided: single-unit houses and mid/high-rise apartments.
- 60 percent of people favor neighborhoods with a walkable environment, and a mix of houses and stores rather than neighborhoods that require more driving between home, work, and play.¹

Housing Choices Have Been at Extreme Ends of The Spectrum

For the past 75 years, we have primarily been building detached single-unit houses and mid-rise/high-rise apartments, without addressing the market needs between these two ends.

Millennials and Baby Boomers²

- 56 percent of millennials and 46 percent of baby boomers want to live in more walkable neighborhoods
- 59 percent of millennials and 27 percent of baby boomers are looking for MMH.

Office Tenants³

Office tenants prefer locations in walkable environments over typical suburban office parks by a ratio of 4 to 1.

Changing Demographics⁴

By 2025, 85 percent of households will not have children, but we are building as if they will. Further, nearly 30 percent of households today are single-person households, and this trend is anticipated to continue. Millennials, baby boomers, and single-person households do not need or want a large yard or house to maintain.

10,000 Baby Boomers Retire Every Day⁵

Half of them retirees have no retirement savings and depend on their social security payments averaging \$1,341 per month. These retirees require smaller and more affordable housing choices.

Sources

³ NAIOP Commercial Real Estate Development Association

⁴ U.S. Census Bureau

⁵ Home.one

Shortage of 3 Million Units

Across the U.S., we are 3 million units short of the demand for small-lot and attached housing units.

Figure 1.4 Housing preferences of Baby Boomers and Millennials
Source: American Planning Association

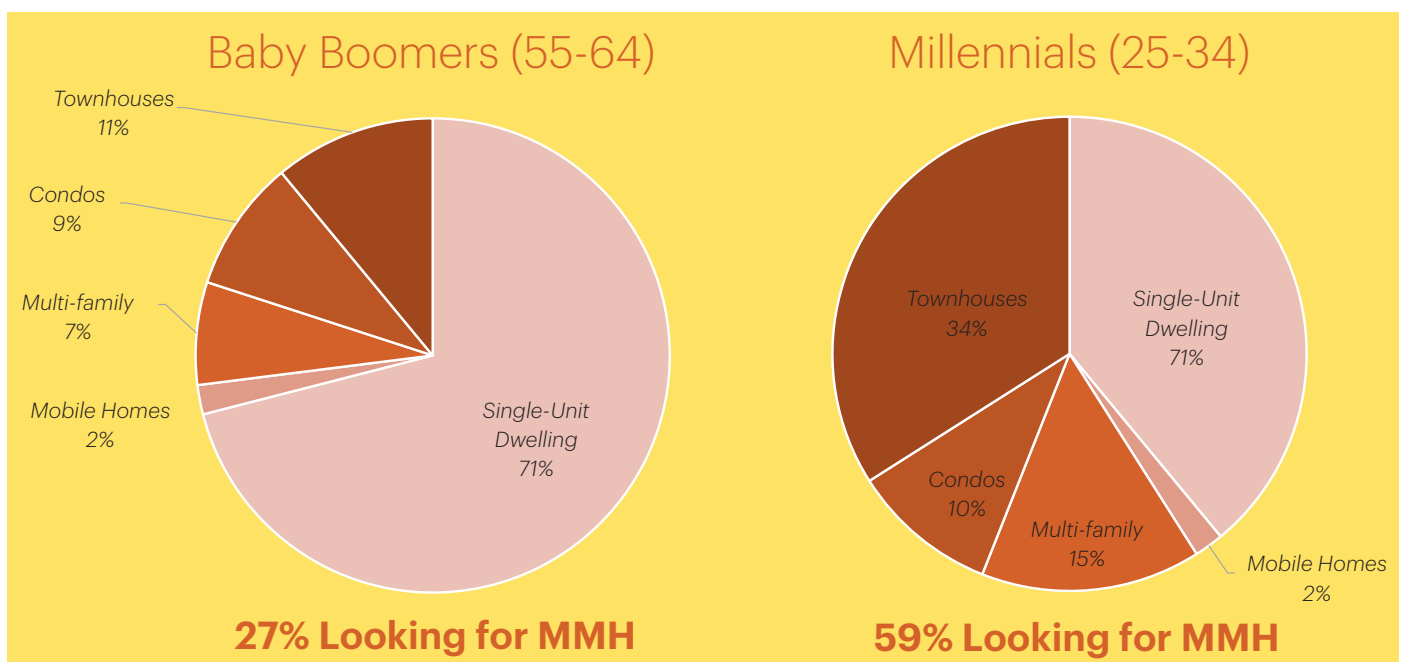

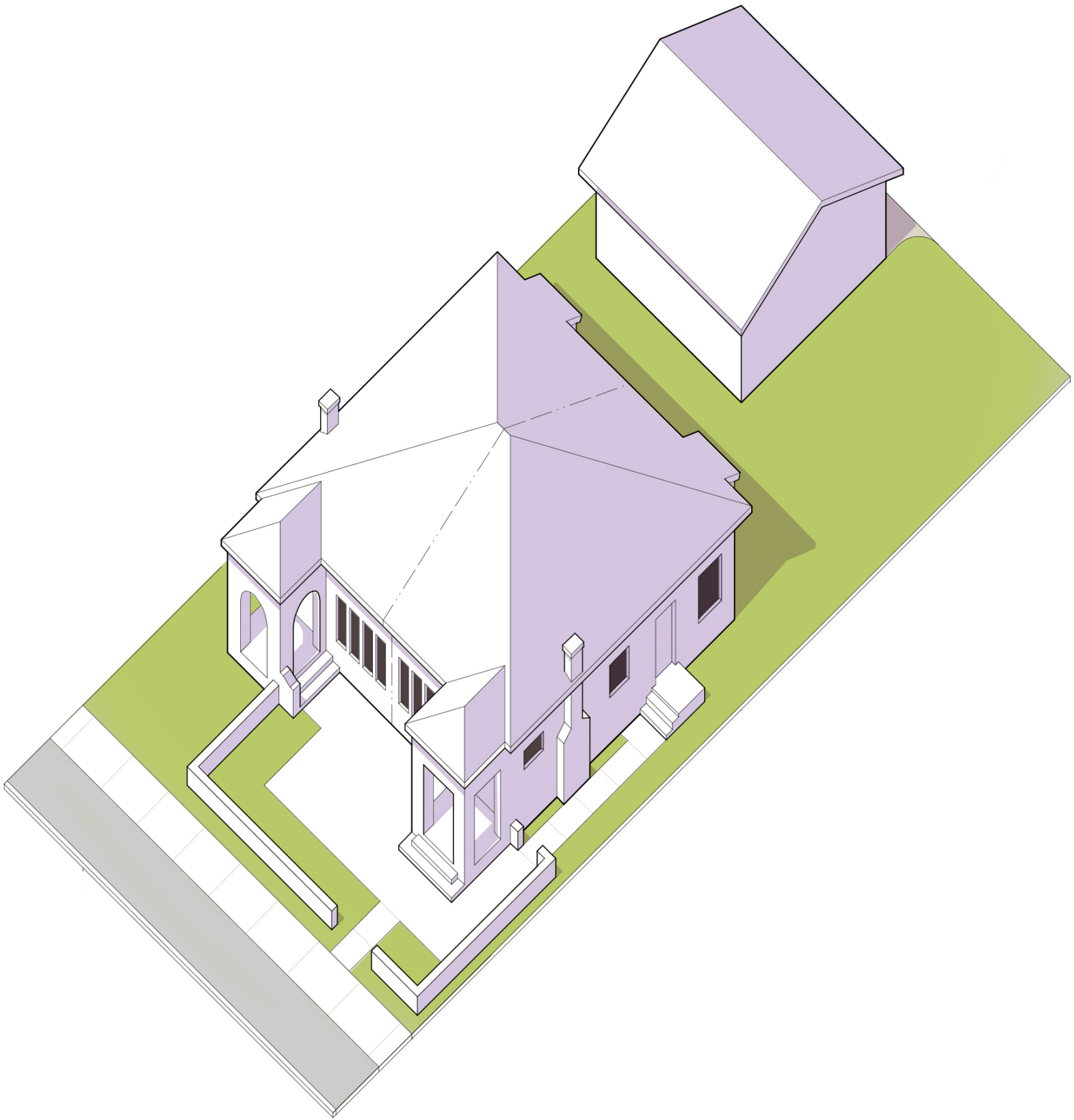

About Missing Middle Housing

CHAPTER

2

In this chapter

What Is Missing Middle Housing (MMH)?	14
What Defines a Missing Middle Building Type?	20
Frontage Types for Missing Middle Housing	34
Missing Middle Housing in the City of Columbia	36
Walkable Centers in Columbia	38
Missing Middle Housing-Ready Neighborhoods	42

2.1

What Is Missing Middle Housing (MMH)?

Missing Middle Housing (MMH) can be defined as house-scale buildings with multiple units in walkable neighborhoods. They are compatible in form and scale with typical single-family homes, and are an effective strategy for "gentle infill" within existing residential neighborhoods.

Responding to The Demand for Walkable Urban Living

The mismatch between current US housing stock and shifting demographics, combined with the growing demand for walkable urban living, has been poignantly defined by recent research and publications by Christopher Nelson and Chris Leinberger, and most recently by the Urban Land Institute's publication "What's Next: Real Estate in the New Economy."

The solution is not as simple as adding more multi-family housing stock using the same housing typologies that have been built over the past couple of decades. Instead, it will be necessary to shift the way that we design, locate, regulate,

and develop homes. As "What's Next" states, "It's a time to rethink and evolve, reinvent and renew." To that end, Missing Middle Housing types such as duplexes, fourplexes, cottage courts, multiplexes, townhouses, and live/work units, are a critical part of the solution and should be in the toolbox of every architect, planner, real estate agent, and developer.

Well-designed and simple, Missing Middle types achieve medium-density yields and provide high-quality, marketable options between the scales of single-unit homes and mid-rise apartments. They are designed to meet the specific needs of shifting demographics and new market demands and are a key



Figure 2.1 Walkable Neighborhoods within a 5-minute walk (blue dashed area) and 10-minute walk (orange dashed areas) surrounding a variety of centers.

Q CLOSER LOOK

Walkable Neighborhood

These are places where a person can easily walk or bike to home, work, or to fulfill most daily needs, including shopping and recreation. The compact form and mix of uses found in a Walkable Neighborhood are anchored by "Walkable Centers": where neighborhood-serving retail, food, services, and employment are located in a pedestrian-oriented

environment, affording multi-modal access throughout the area. These environments accommodate but do not depend on the use of automobiles for most daily needs. This was the standard model developed prior to the 1940s. See Section 2.3 for more information on "Walkable Centers".



component in neighborhoods offering diverse housing choices. They are called “missing” because very few of these housing types have been built since the early 1940s due to regulatory constraints, the shift to auto-dependent patterns of development, and the incentivization of single-unit homeownership by the federal government.

Before the 1940s, they were a natural part of the housing mix, helping to provide housing choices to people at a variety of stages in their life and income levels. Communities and organizations, including AARP, are realizing that Missing Middle Housing is important in helping neighborhoods thrive while providing housing choices as people age and can stay in their neighborhood.

A Walkable Context

A critical characteristic of the MMH types is that they are most effective when located within an existing or newly created walkable context. Buyers or renters of these housing types are choosing to trade larger suburban housing for less space, less yard to maintain, and proximity to services and amenities such as restaurants, bars, markets, services, and employment. Figure 2.1 shows a “walkable neighborhood” in Columbia surrounding mixed-use “walkable centers” that are not car-dependent.

Medium-Density but Lower Perceived Densities

Missing Middle building types typically range in density from 8 du/acre to up to 52 du/acre, depending on the building type and lot size. It is important not to get distracted with the density numbers when thinking about these types. Density is an unpredictable factor that depends on many variables; as shown by the examples in Figures 2.2 and 2.3. Built form is more clearly articulated by factors such as building height, footprint and massing. Due to the small footprint of MMH types, and the fact that they are usually mixed with a variety of building types, even on an individual block, their perceived density is usually quite low—they do not look like dense buildings (even though their densities may be quite high).

A combination of these MMH types provides a neighborhood with a minimum average of 16 du/acre. This is generally the threshold at which an environment has enough households to be transit-supportive; and at which neighborhood-serving retail and other services become financially viable.

Small Footprints and Blended Densities

A common characteristic of MMH types is their small-to-medium-sized building footprints. The largest of the Missing Middle types have a typical main body width of about 50 to 60 feet and can be

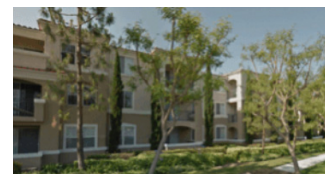

Figure 2.2 49 units, 30 du/ acre
Building 175' x 165', 3 Stories

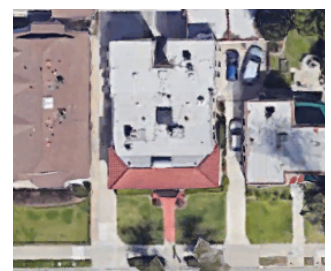
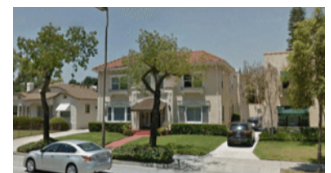

Figure 2.3 5 units, 29 du/ acre
Building 40' x 65', 2 Stories

up to 80 feet overall when secondary wings are included. These sizes are comparable to a large estate home. This characteristic makes these types ideal for urban infill, even in older neighborhoods that were originally developed as single-unit neighborhoods, but could be designated to allow slightly higher intensities.

Smaller, Well-Designed Units

The starting point for MMH is smaller-sized units (500 to 1,000 square feet). A common mistake by architects or builders new to building MMH is trying to force suburban unit types and sizes into urban contexts and MMH types. The challenge is to create small spaces that are well designed, comfortable, and usable. As an added benefit, smaller unit sizes can help developers keep their costs down, improving the proforma performance of a project, while making housing options

available to a larger group of buyers or renters at a lower price point.

Off-Street Parking Does Not Drive The Site Plan

Trying to provide too much on-site parking can make a MMH develop project not viable. If large parking areas are provided or required, these buildings become very inefficient from a development potential or yield standpoint, reducing the 16 du/acre density threshold. As a starting point, these units should provide no more than one off-street parking space per unit. To enable these lower off-street parking requirements, on-street parking is required to be available adjacent to the units. Housing design that forces too much on-site parking also compromises the occupant's experience of entering the building or "coming home" and the relationship with its context, especially in an infill condition, which can greatly impact marketability.

Figure 2.4 *The simple forms, smaller size, and compatibility with Type V construction help maximize affordability and investment returns, and are consistent with the construction strategies familiar to most residential homebuilders, as shown in this under-construction MMH project in Papillion, Nebraska.*



Simple Construction

Because of their simple forms, smaller size, and Type V construction, Missing Middle building types can help developers maximize affordability and returns without compromising quality by providing housing types that are simple and affordable to build.

Creating Community

MMH creates community through the integration of shared community spaces within the types, as is the case for courtyard buildings or cottage courts, or simply from the proximity they provide to the community within a building and/or the neighborhood. This is an important aspect, in particular within the growing market of single-person households (which is at nearly 30 percent of all households, nationally) that want to be part of a community. This has been especially true for single women who have proven to be a strong market for these MMH types, in particular cottage courts.

Marketability

A final critical characteristic is that these housing types are very close in scale to single-unit homes and provide a similar user experience. For example, in these types, you enter through a front porch facing the street instead of walking down a long corridor or anonymous stairway to

get to your unit. This makes the mental shift for potential buyers and renters much less drastic than making a shift to live in a large apartment building. This, combined with the fact that many baby boomers likely grew up in or near to similar housing types in urban areas or had relatives that did, enables them to easily relate to these housing types.

Missing Middle Housing offers an opportunity for architects, planners, real estate professionals, and developers to think outside the box and to begin to create immediate, viable solutions to address the mismatch between the housing stock and what the market is demanding: vibrant, diverse, sustainable, walkable urban places. Missing Middle Housing types should be integrated into comprehensive and regional planning, zoning code updates, TOD strategies, and business models for developers and builders who want to be at the forefront of this paradigm shift.

Larger Missing Middle Housing

"Larger" Missing Middle Housing refers to multi-unit buildings taller and deeper than typical MMH types, that still fit on the size of lots you would find in a single-unit neighborhood.

Larger MMH, when used strategically, can still be compatible with house-scale neighborhoods while likely achieving higher financial feasibility than typical MMH types. The following best practices should be considered:

- Use Larger MMH types in transition areas of a neighborhood, connecting to more intense nodes or transit centers.
 - Allow more lot coverage and/or deeper building footprints than for typical MMH.
 - Require rear setbacks for Larger MMH based on size of neighboring rear setbacks (up to 20 feet maximum)
 - Reduce total stories along the rear adjacent to neighboring houses.
- Larger MMH is most effective where a greater degree of change is happening or desired.

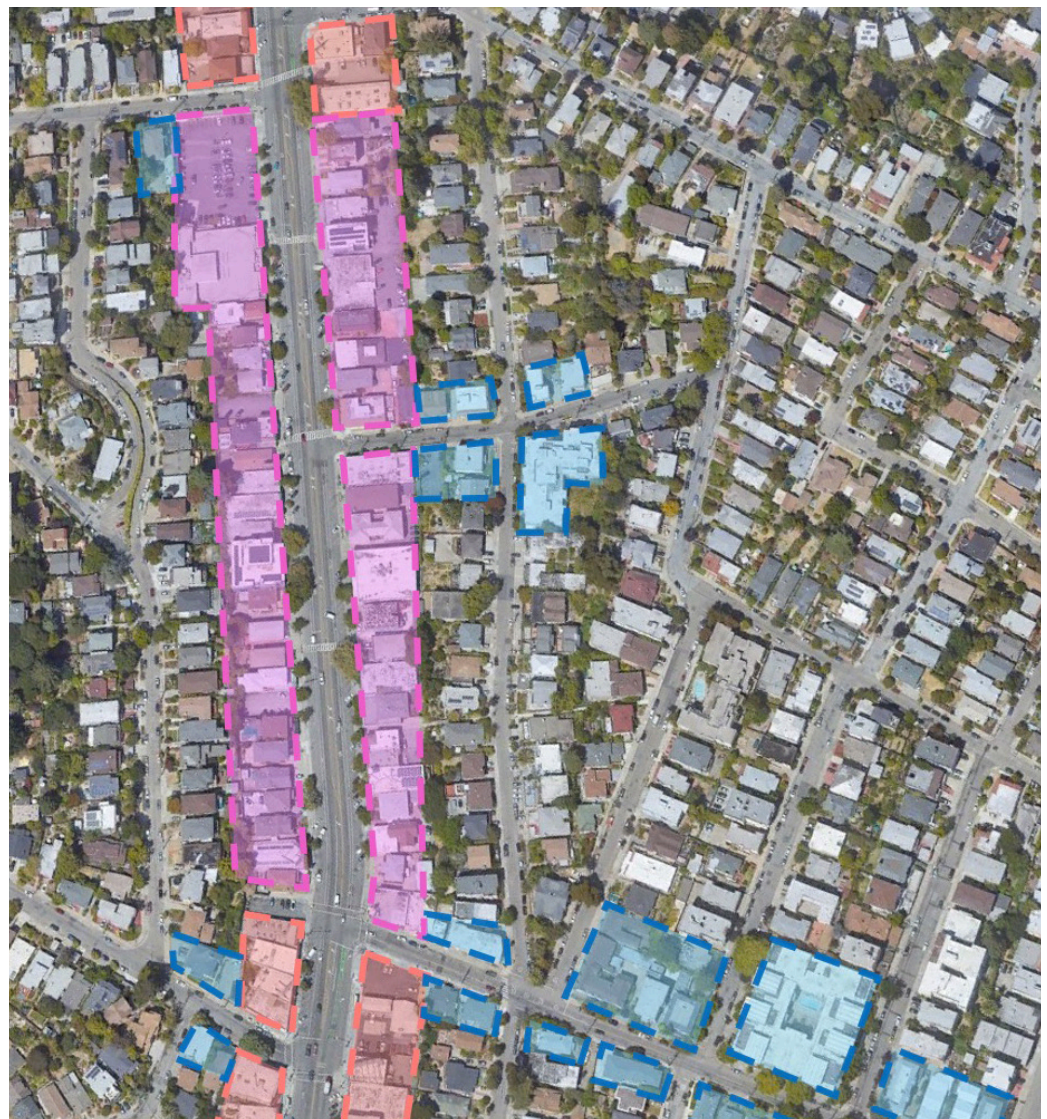
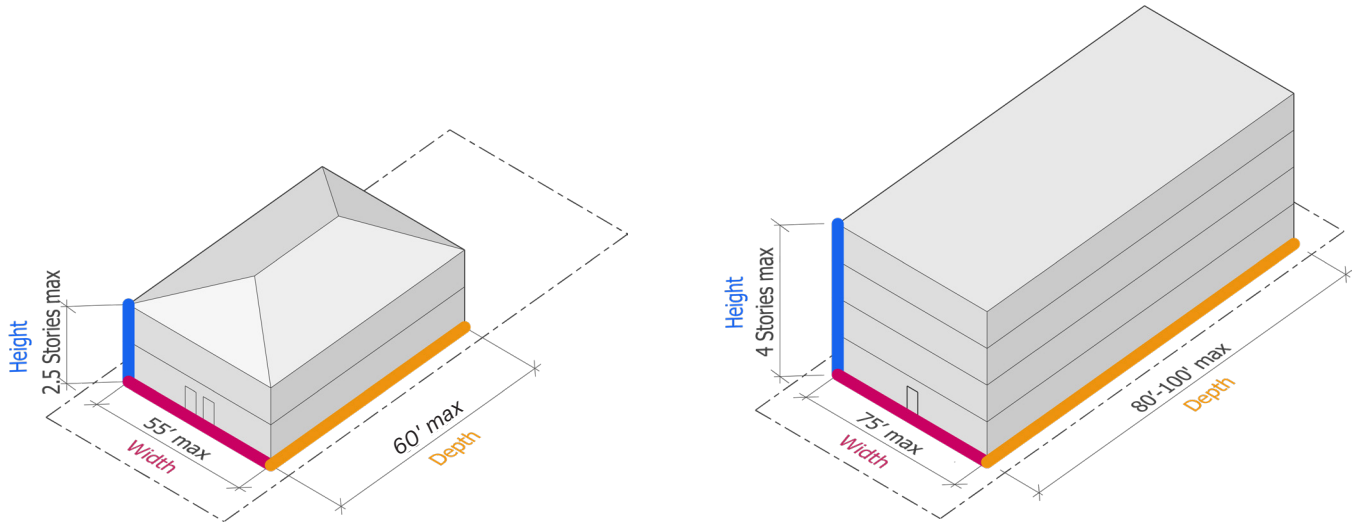

Figure 2.5 Example of where to consider locating Larger MMH in a neighborhood and along a corridor.

Key

-  Concentrate ground floor shops, services, food uses along major corridor
-  Larger MMH along major corridor as transition to adjacent low intensity neighborhood
-  Secondary locations for Larger MMH in response to ongoing change or desire for change

Figure 2.6 The diagrams and images below show a comparison between typical MMH and Large MMH.



Missing Middle Housing (MMH)

Located within and along edges of low-to-moderate intensity neighborhoods.

Larger Missing Middle Housing (Larger MMH)

Located along corridors and edges of neighborhoods where substantial change is happening or desired.



Fourplex (Typical MMH)

4 units
Columbia, SC



Multiplex Large (Larger MMH)

6+ units
Columbia, SC

2.2

What Defines a Missing Middle Building Type?

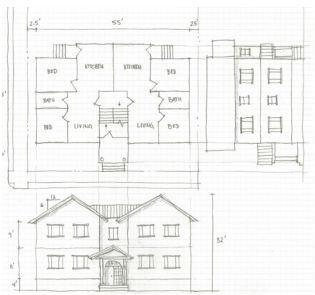

Figure 2.7 MMH walking tour (top) and example documentation of a MMH type observed during the tour (bottom)

Missing Middle Housing includes a range of building types. Each type has unique attributes that must be considered for employing these types most effectively.

Importance of Building Form Elements for MMH

In order for Missing Middle Housing types to fit within the physical form of residential neighborhoods, it is important to understand the elements of building form and design that promote a house-scale look and feel.

Building types provide a way to establish a common vocabulary that promotes house-scale building design. By providing this high degree of specificity, it is possible to promote more predictable outcomes in

terms of what gets built. Higher degrees of predictability make it easier for the community to support new development projects since clear expectations can be set in terms of building form at the beginning of the development project.

Q CLOSER LOOK

How to Identify MMH Building Types in Columbia

Taking an inventory of existing MMH types is the first step in creating building type standards. Many Missing Middle types may be non-conforming with existing zoning, or may have been converted into other uses, such as a single-unit home or offices, so it's important to do on-the-ground research to avoid overlooking existing examples. Mailboxes, electrical and gas meters, and window type/composition on the facade can indicate a Missing Middle type. Existing Missing Middle types can provide guidance for calibrating zoning standards. Measuring

lot dimensions, building footprints, frontage details, parking configurations, building height, location of units within the buildings, and location of building and/or unit entrances can help to define the unique characteristics of MMH types in Columbia. Photo documentation also helps to inform standards, as well as providing examples of intended building form and character that can inform both new development and infill projects.

Characteristics of Missing Middle Building Types¹

Missing Middle Housing is not a new type of building. These house-scale building types exist in cities and towns across the country. These types were a fundamental part of pre-1940s neighborhoods, and many examples exist in Columbia's more historic neighborhoods.

All Missing Middle Housing types share the following important characteristics:

- **Height.** Two to two and a half stories maximum (a third story is an exception; only allowed with careful consideration of form and scale impact.)
- **Multiple units per building.** Typically twelve units or less per building, with a maximum of 20 units for Large MMH types.
- **Footprint.** Typical main body width of 50 to 60 feet along the street, that can be up to 80 feet overall when secondary "wings" are included (set back or at a lower height than the main body).

- **Off-street parking.** Recommend requiring no more than one off-street parking space per unit. This is viable when near to services, retail, and the availability of on-street parking. Detached parking structures can help to maintain a house-scale character for the primary building in neighborhoods with narrower houses.
- **On-site open space.** Private open space is not needed and should not be required. Shared open space is important and should be required in the form of a rear yard, sometimes as a wide side yard, or a courtyard.
- **Driveways.** Generally, driveway design for MMH types should match the neighborhood context on a per-lot basis. If no alley is present, single-lane wide driveways are recommended when possible to avoid building frontages dominated by parking.

Sources

¹*Missing Middle Housing, Thinking Big and Building Small to Respond to Today's Housing Crisis*, by Dan Parolek, published by Island Press

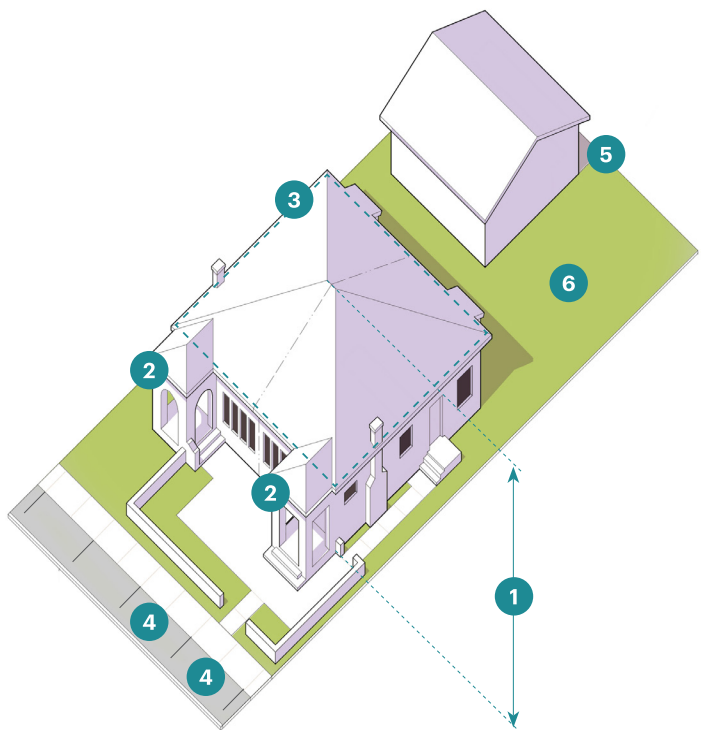

Figure 2.8 Important features to regulate

Key

- 1 Max. Height
- 2 Number of Units
- 3 Footprint/ Main Body Dimensions
- 4 On-Street Parking
- 5 Driveways (if any)
- 6 On-Site Open Space

Duplex Side-by-Side

Description

A small- to medium-sized building that consists of two dwelling units, one next to the other, both of which face and are entered from the street.

A variation of this is the "front-to-back" duplex. This variation and the side-by-side building type are meant to provide two units within the footprint of a single-unit building. These are distinct from the non-recommended practice of attaching two single-unit houses to form two attached units. This latter approach often results in a building that is larger and is out of scale with its single-unit neighbors.



Accessory Dwelling Unit (ADU)

The ADU can be located above the garage building to provide an additional unit separate from the main building.

2

Duplex Side-by-Side		
Number of Units	Vehicular Access	
	Front	Rear
Lot Width (ft)	50' - 75'	40' - 70'
Lot Depth (ft)	100' - 150'	100' - 150'
Resultant Density (du/acre)		
Without ADU	8 - 17	8 - 22
With ADU	12 - 26	12 - 33

Duplex Stacked

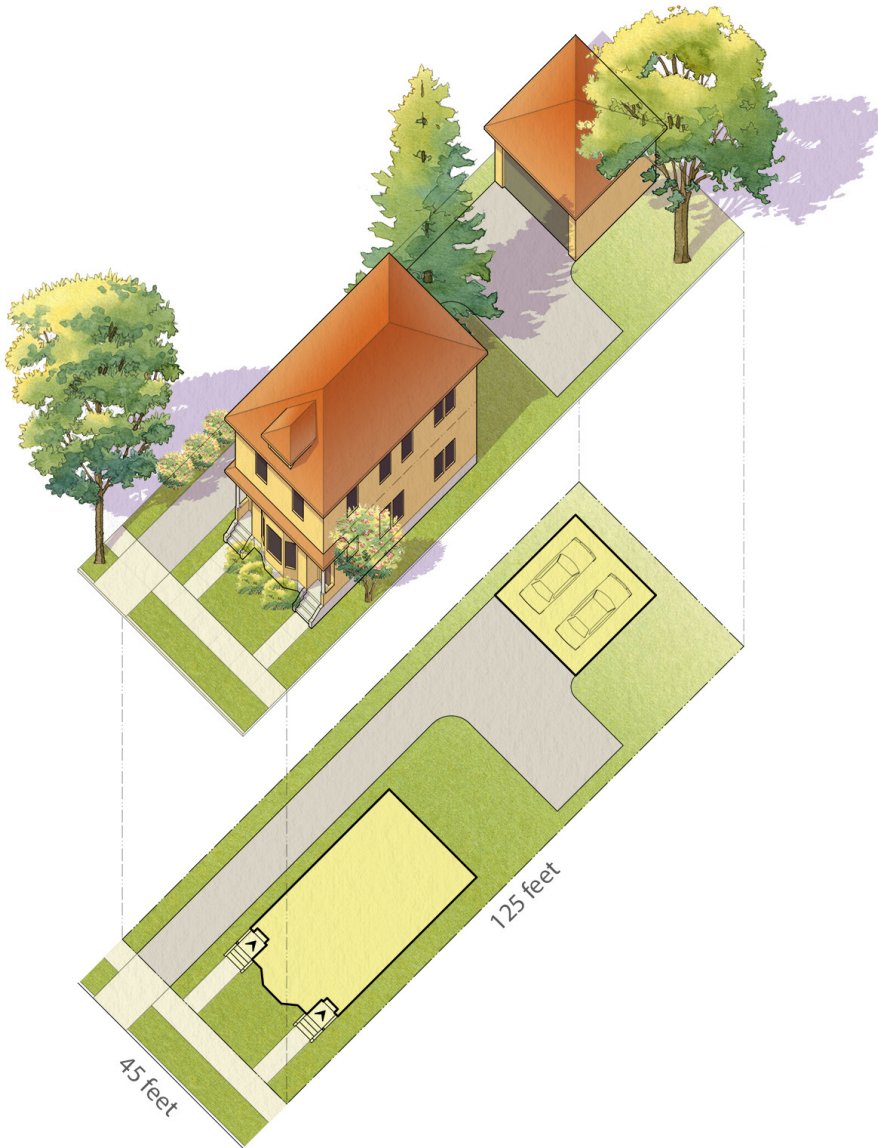

Description

A small- to medium-sized building that consists of two stacked dwelling units, one on top of the other, both of which face and are entered from the street.



Accessory Dwelling Unit (ADU)

The ADU can be located above the garage building to provide an additional unit separate from the main building.

Duplex Stacked			
Number of Units	Vehicular Access		
	Front	Rear	
Lot Width (ft)	40' - 75'	30' - 70'	
Lot Depth (ft)	100' - 150'	100' - 150'	
Resultant Density (du/acre)			
Without ADU	8 - 22	8 - 29	
With ADU	12 - 33	12 - 44	

2

Cottage Court/Bungalow Court

Description

A series of small, detached buildings on a lot arranged to define a shared court that is typically perpendicular to the street. The shared court takes the place of a private rear yard and is an important community-enhancing element.

The Accessory Dwelling Unit (ADU) is not recommended for this type due to the limited number of available off-street parking spaces.

A larger version of this type is known as the “pocket neighborhood”. This type differs from the cottage court primarily by site size. Typically, the pocket neighborhood is on a site at least twice as large as the cottage court, has larger dwellings and a variety of housing types (houses, duplexes, etc.).



Cottage Court/ Bungalow Court

Number of Units

5-10

Vehicular Access

Front

Rear

Lot Width (ft)	100' - 160'	90' - 150'
Lot Depth (ft)	100' - 150'	100' - 150'
Resultant Density (du/acre)		
Without ADU	18 - 22	19 - 24
With ADU	n/a	n/a

Fourplex

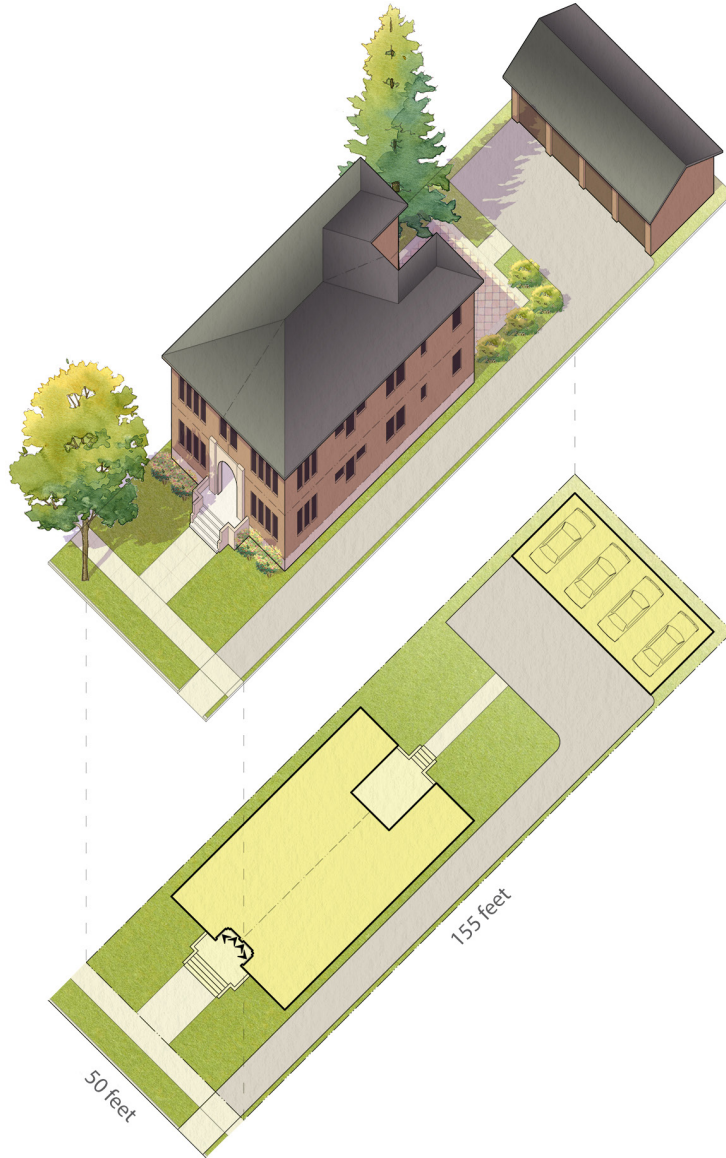

Description

A medium-sized building that consists of four units: typically two on the ground floor and up to two above with a shared entry from the street. Although this type shows four units, a triplex has the same built form characteristics but contains three units, not four.



Accessory Dwelling Unit (ADU)

The ADU can be located above the garage building to provide an additional unit separate from the main building.

Fourplex

Number of Units

Vehicular Access

Front

Rear

Lot Width (ft)	55' - 80'	50' - 70'
Lot Depth (ft)	100' - 150'	100' - 150'

Resultant Density (du/acre)

Without ADU	15 - 32	17 - 35
With ADU	18 - 40	21 - 44

4

Multiplex Small

Description

A medium-sized building that consists of five to 10 side-by-side and/or stacked dwelling units, typically with one shared entry or individual entries along the front and sometimes along one or both sides.

The Accessory Dwelling Unit (ADU) is not recommended for this type due to the limited number of available off-street parking spaces. In some situations, this type provides 0.5 parking spaces per unit at the lower end of the range of units.

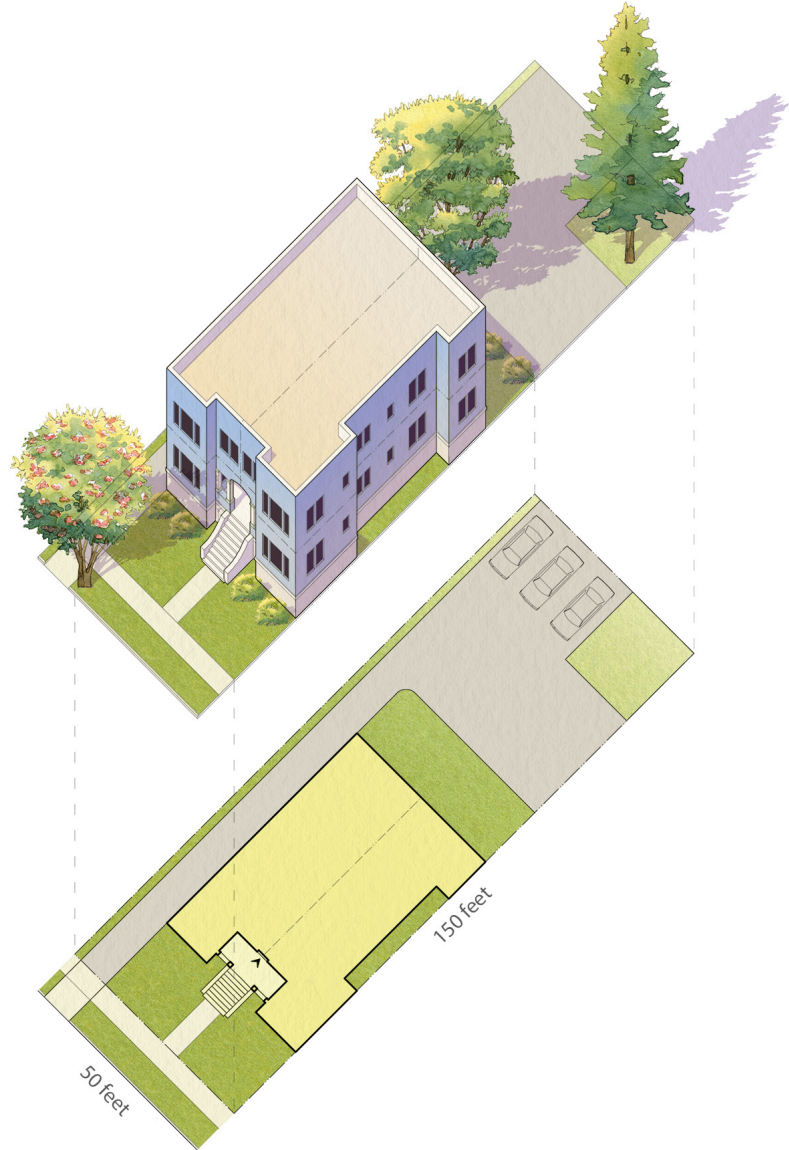

Multiplex Small			
Number of Units	Vehicular Access		
		Front	Rear
5-10	Lot Width (ft)	55' - 80'	50' - 70'
	Lot Depth (ft)	100' - 150'	100' - 150'
	Resultant Density (du/acre)		
	Without ADU	36 - 40	41 - 44
	With ADU	n/a	n/a

Multiplex Large

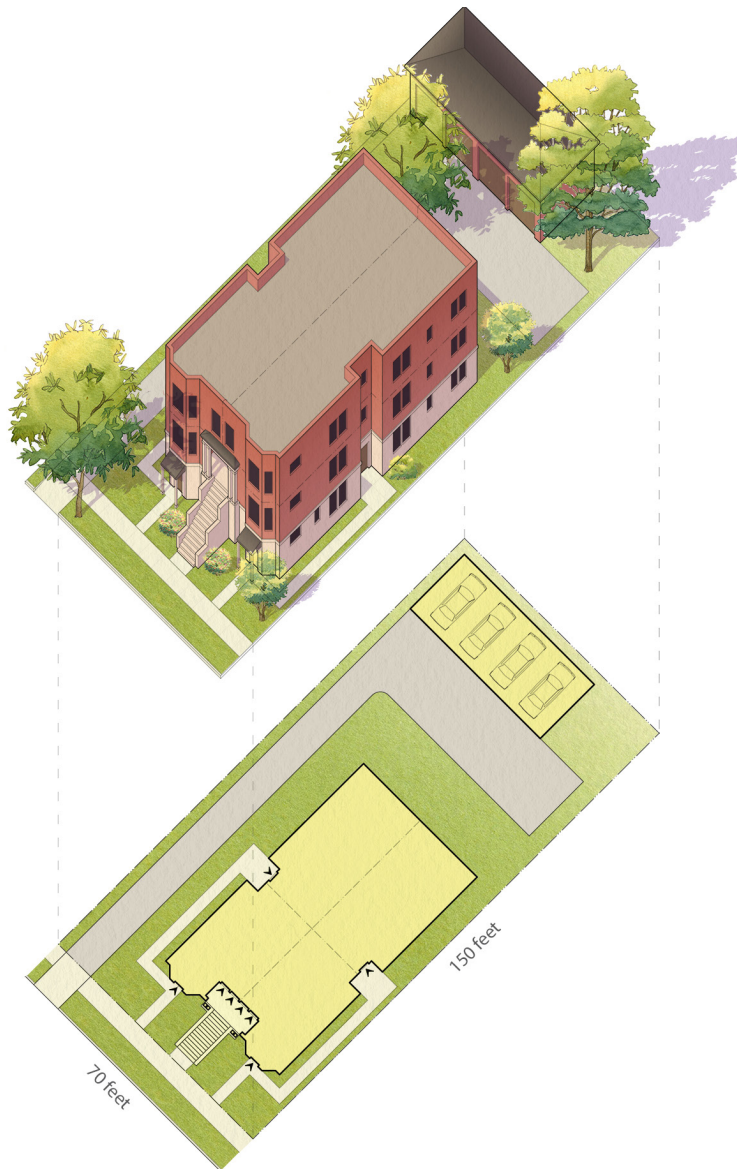

Description

A medium-to-large-sized structure that consists of six to 18 side-by-side and/or stacked dwelling units, typically with one shared entry or individual entries along the front and sometimes along one or both sides.

The Accessory Dwelling Unit (ADU) is not recommended for this type due to the limited number of available off-street parking spaces. In some situations, this type provides 0.5 parking spaces per unit at the lower end of the range of units.

Multiplex Large			
Number of Units	Vehicular Access		
	Front	Rear	
6-18	Lot Width (ft)	70' - 120'	60' - 110'
	Lot Depth (ft)	100' - 150'	100' - 150'
	Resultant Density (du/acre)		
	Without ADU	37 - 44	44 - 48
	With ADU	n/a	n/a

Courtyard Building

Description

A medium- to large-sized building or up to three small-to-medium size detached buildings consisting of multiple side-by-side and/or stacked dwelling units arranged around a shared courtyard. Dwellings are accessed from the courtyard. Typically, each unit has its own individual entry or shares a common entry with up to three units.

The Accessory Dwelling Unit (ADU) is not recommended for this type due to the limited number of available off-street parking spaces.

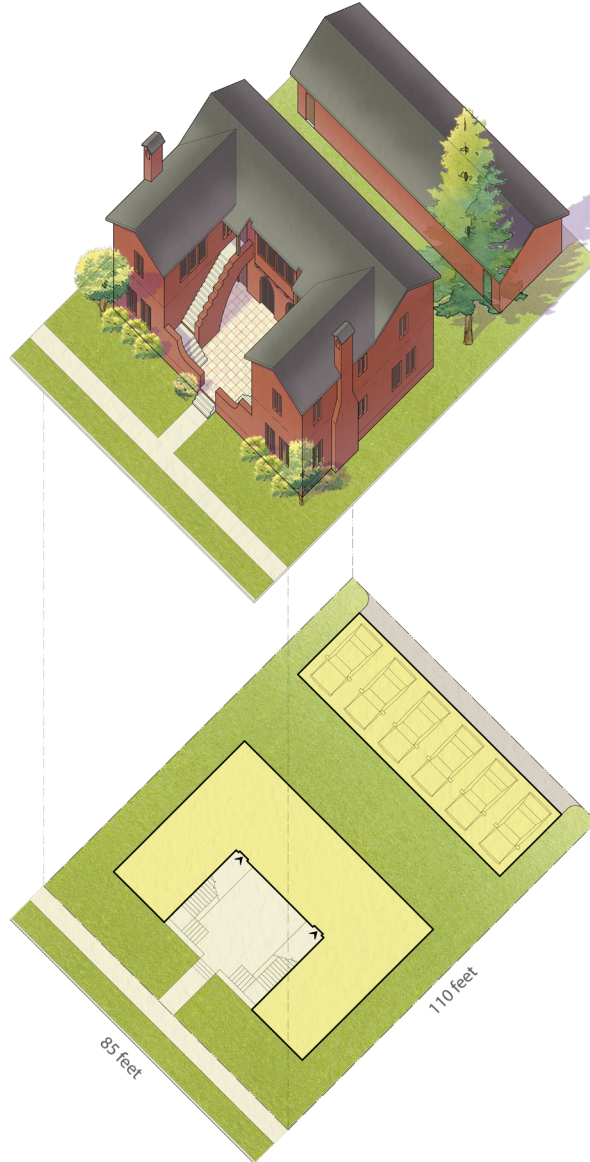

Courtyard Building			
Number of Units	Vehicular Access		
	Front	Rear	
Lot Width (ft)	95' - 150'	85' - 140'	
Lot Depth (ft)	110' - 175'	110' - 175'	
6-20	Resultant Density (du/acre)		
	Without ADU	25 - 33	28 - 36
	With ADU	n/a	n/a

Townhouse

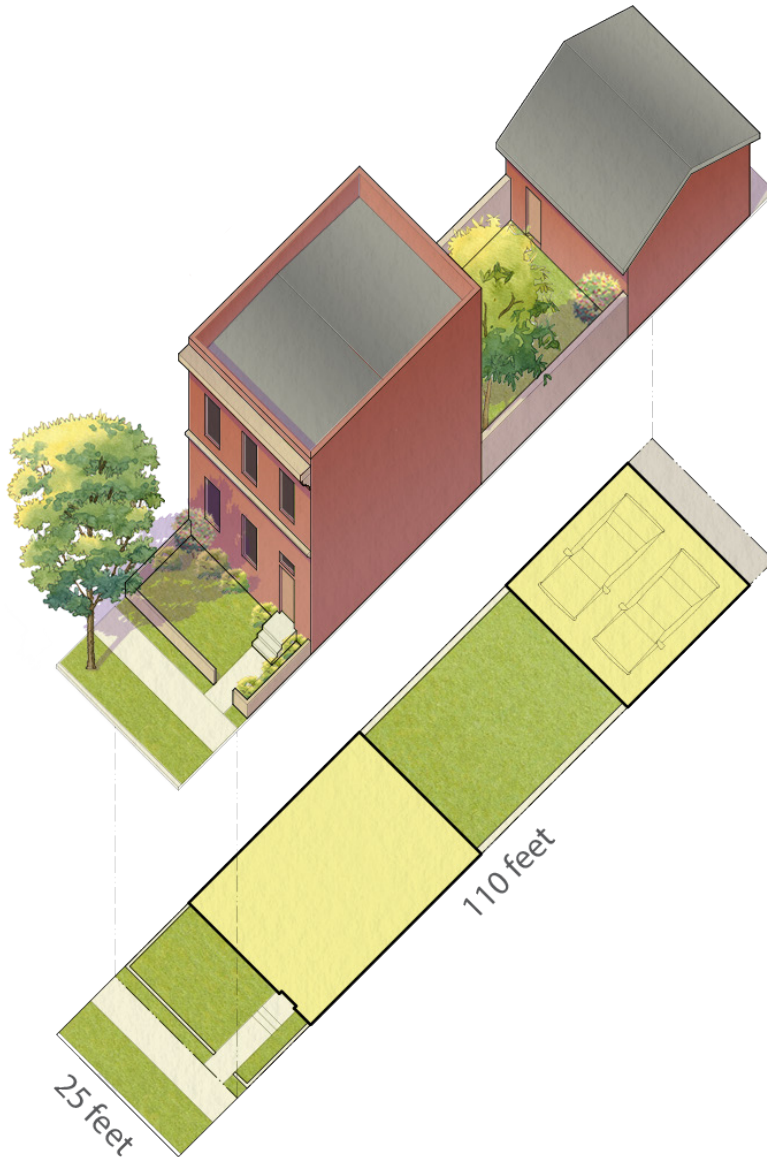

Description

A small- to medium-sized building with one dwelling that is attached to other townhouses in an array of up to four, sometimes up to six, depending on the context.

A more intense version of this type is the “townhouse flat” that divides the building vertically into two to three flats.



Accessory Dwelling Unit (ADU)

The ADU can be located above the garage building to provide an additional unit separate from the main building.

Townhouse		
Number of Units	Vehicular Access	
	Front	Rear
Lot Width (ft)	n/a	16' - 45'
Lot Depth (ft)	n/a	85' - 120'
Resultant Density (du/acre)		
Without ADU	n/a	8 - 32
With ADU	n/a	16 - 64

1

Live/Work

Description

A small- to medium-sized attached or detached building consisting of one dwelling unit above or behind a flexible ground floor space for residential, service, or retail uses. Both the primary ground-floor flex space and the second unit are owned by one entity.

These types can be arranged to form what looks like a neighborhood main street building.

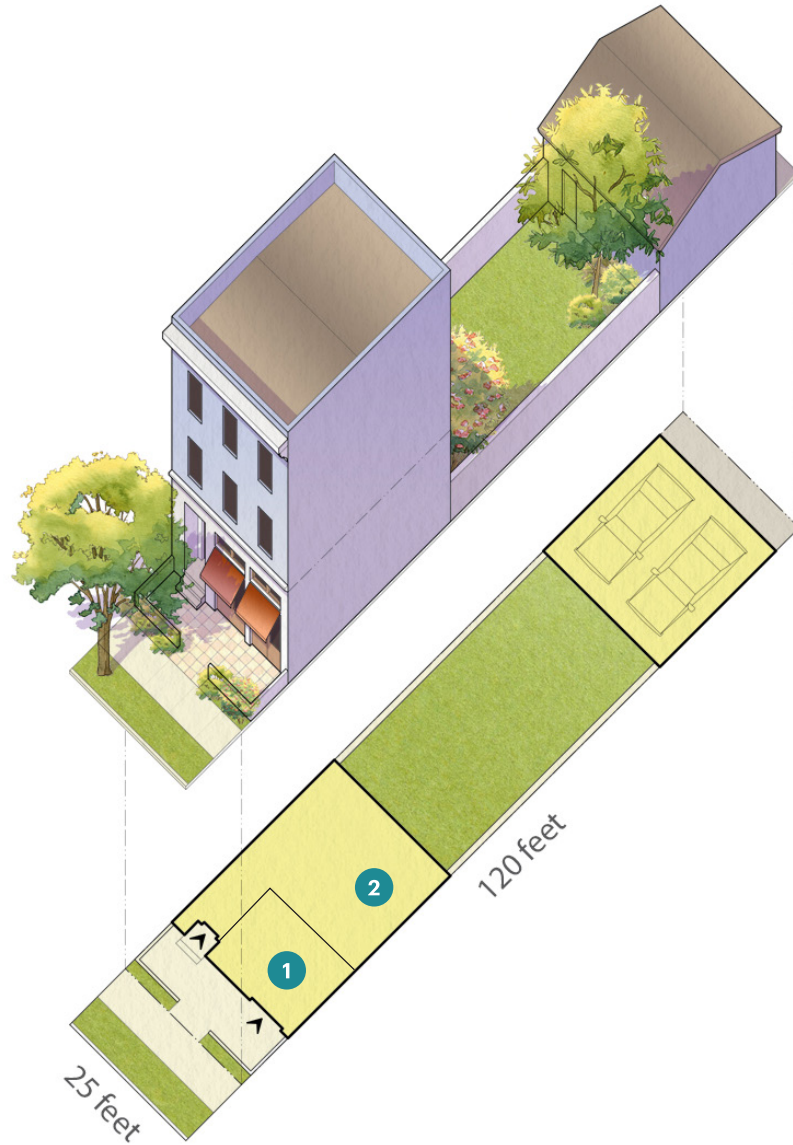

Key

- 1 Flex Space
- 2 Dwelling Unit



Accessory Dwelling Unit (ADU)

The ADU can be located above the garage building to provide an additional unit separate from the main building.

Live/Work			
Number of Units	Vehicular Access		
	Front	Rear	
1	Lot Width (ft)	n/a	16' - 45'
	Lot Depth (ft)	n/a	85' - 120'
	Resultant Density (du/acre)		
	Without ADU	n/a	8 - 32
	With ADU	n/a	16 - 64

House-Scale Buildings

Main body only

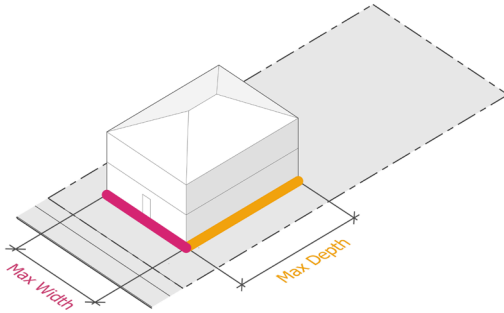

Main body with side and rear wings

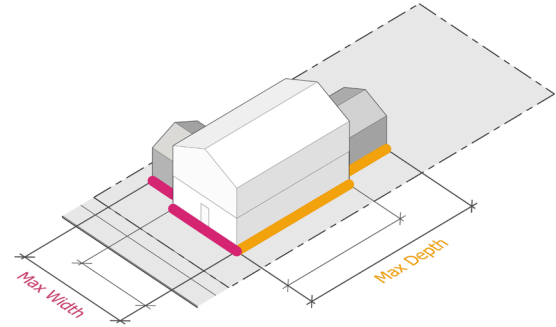

Block-Scale Buildings

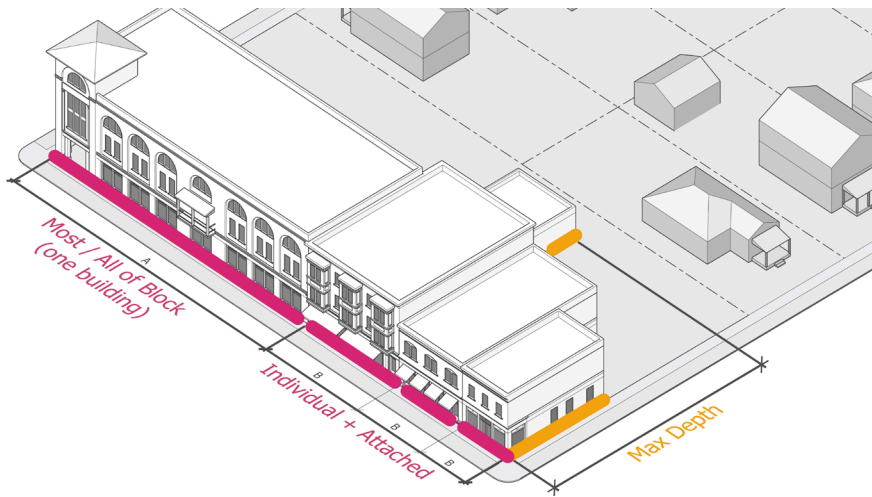

Q CLOSER LOOK

Building Types Categories

Building types fall into one of two categories: house-scale and block-scale.

House-scale buildings are the size of a house, typically ranging in footprint from as small as 25 feet up to 80 feet overall, including wings.

Block-scale buildings are individually as large as most or all of a block or, when arranged together along a street, appear as long as most or all of a block.



Figure 2.9 House-scale townhouses are arranged as a "run" of 2-4 units, up to 2 stories tall. This building type is appropriate in lower-intensity neighborhoods because it maintains the scale of a large single-unit house.

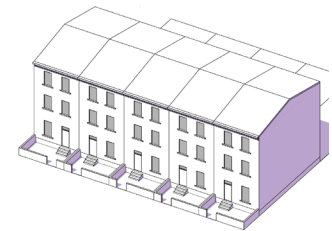

Figure 2.10 Block-scale townhouses consist of 4-8 units, up to 3 stories tall. This building type is appropriate in moderate to high-intensity neighborhoods since it is larger in scale than a single-unit house.

The Palette of Missing Middle Housing Types



Duplex Side-by-Side
2 units



Duplex Stacked
2 units



Cottage Court¹
5-10 units



Fourplex²
4 units

Recommended Characteristics of Missing Middle Housing Types

Vehicular Access	Front	Rear	Front	Rear	Front	Rear	Front	Rear
Max. Height (Stories)	2.5		2.5		1.5		2.5	
Lot Width (ft)	50' - 75'	40' - 70'	40' - 75'	30' - 70'	100' - 160'	90' - 150'	55' - 80'	50' - 70'
Lot Depth (ft)	100' - 150'	100' - 150'	100' - 150'	100' - 150'	100' - 150'	100' - 150'	100' - 150'	100' - 150'
Area of Lot (sf)	5,000 - 11,250	4,000 - 10,500	4,000 - 11,250	3,000 - 10,500	10,000 - 24,000	9,000 - 22,500	5,500 - 12,000	5,000 - 10,500
Resultant Density³								
Without ADU	8 - 17	8 - 22	8 - 22	8 - 29	18 - 22 ³	19 - 24 ³	15 - 32	17 - 35
With ADU	12 - 26	12 - 33	12 - 33	12 - 44	n/a	n/a	18 - 40	21 - 44

Assumptions: 15' front setback, 5' side setback, 12' driveway width

¹Variation: Pocket Neighborhood. The lot for this variation is the size of most of a block or up to an entire block, and the shared court is much larger, or there are several shared courts. The individual cottages are expanded to include a mix of duplex and fourplex buildings.

²A triplex has the same built form characteristics as a fourplex but contains only three units.



Figure 2.11 Example of current MMH development in Columbia

Missing Middle Housing Palette

The palette of MMH types above identifies the typical lot dimensions for each type. The minimum is what each type needs to provide a high quality living environment for residents, and the maximum is the size beyond which lots become too large to deliver the type of compact development that supports walkable environments. These dimensions need to be adjusted to each community and its particular lot patterns.

The resultant density is the number that results from designing units that reasonably fit in each MMH building type. This is different from density regulations that predetermine how many units are allowed without regard for what can actually fit well.

In addition, the results vary depending on front or rear vehicular access to parking.



Multiplex Small
5-10 units



Multiplex Large
6-18 units



Courtyard Building
6-20 units



Townhouse
1 unit

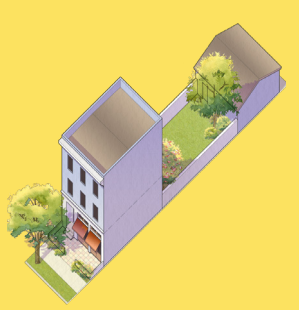

Live/Work
1 unit

Front	Rear	Front	Rear	Front	Rear	Front	Rear	Front	Rear
2.5		2.5 (3 ³)		2.5 (3 ³)		2.5 (3 ³)		2.5 (3 ³)	
55' - 80'	50' - 70'	70' - 120'	60' - 110'	95' - 150'	85' - 140'	n/a	16' - 45'	n/a	16' - 45'
100' - 150'	100' - 150'	100' - 150'	100' - 150'	110' - 175'	110' - 175'	n/a	85' - 120'	n/a	85' - 120'
5,500 - 12,000	5,000 - 10,500	7,000 - 18,000	6,000 - 16,500	10,450 - 26,250	9,350 - 24,500	n/a	1,360 - 5,400	n/a	1,360 - 5,400
36 - 40 ³	41 - 44 ³	37 - 44 ³	44 - 48 ³	25 - 33 ³	28 - 36 ³	n/a	8 - 32	n/a	8 - 32
n/a	n/a	n/a	n/a	n/a	n/a	n/a	16 - 64	n/a	16 - 64

³In more intense neighborhoods, this type can be designed to have a third story, or a portion of a third story, depending on the intended physical character of the neighborhood.

⁴In order to calculate the resultant density for types that have a range of dwelling units, we paired the minimum number of dwelling units with the smallest lot area and the maximum number of dwelling units with the largest lot area.

Although lot area can be used as a regulating factor, it should not be the primary factor. Instead, lot width and the resulting building width should be the primary regulating factors, as these provide for more targeted regulations that have a greater impact on the quality of the public realm and help to deliver more predictable built results in terms of building form.

These dimensions are the results of years of on-the-ground research and design work for private and public sector clients by Opticos. These are

meant as a starting point, and should be calibrated for the specific on-the-ground conditions and desired community form wherever Missing Middle Housing types are desired.

The density ranges for each type correspond to the lower number of units for each with its smaller lot dimensions, and the higher number of units with its larger lot dimensions.

2.3 Frontage Types for Missing Middle Housing

A defining characteristic of MMH types is the way these buildings are designed with "active frontages" to promote everyday interaction.

What is a Frontage?

A "frontage" is defined as the component of a building that provides an important transition and interface between the public realm (street and sidewalk) and the private realm (building facade).

The ultimate intent of regulating frontages is to ensure, after a building is located appropriately on its lot, that its interface with the public realm and the transition between the two are detailed appropriately.

The names of the frontage types depicted below indicate their particular configuration or function and are based

on examples found in cities across the country. Some types may be more or less common in Columbia. An on-the-ground survey can establish which types are most representative of the character of buildings in Columbia.

Why Frontages Are Important for Missing Middle Housing

Missing Middle Housing (MMH) types are house-scale and generally look like they could be a large single-unit home. Frontage types that are consistent with those used on single-unit homes, such as porches and stoops, help Missing Middle types contribute to the residential look and

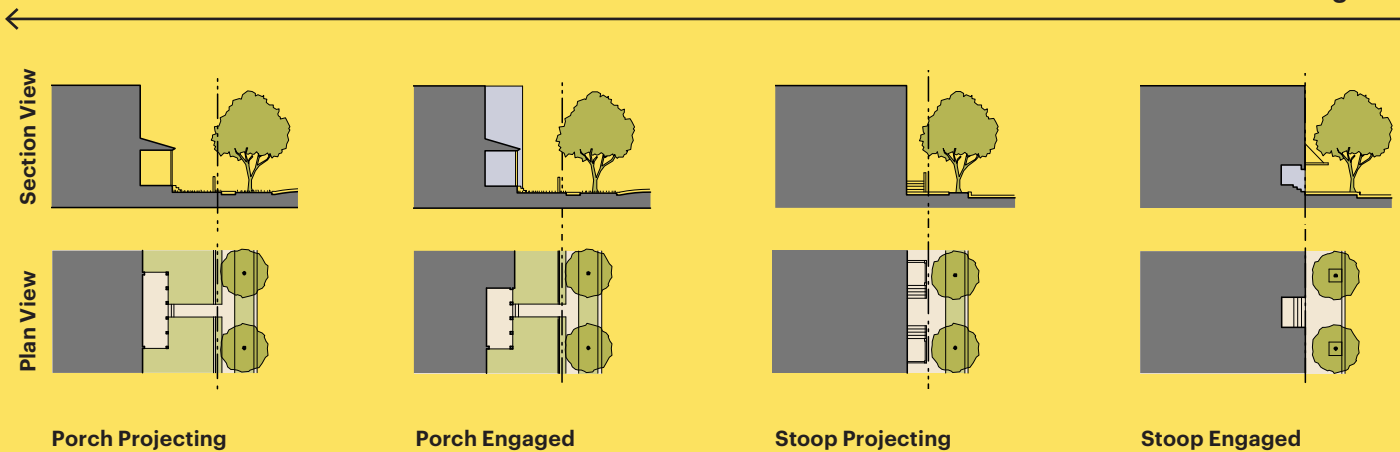

Figure 2.12 Example of projecting porch MMH frontage in Columbia. Upper-story units in the building are accessed by a single, shared entry that leads to a hall or small lobby area.

Q CLOSER LOOK

Spectrum of Frontage Types

Common MMH Frontages



Neighborhood Environment



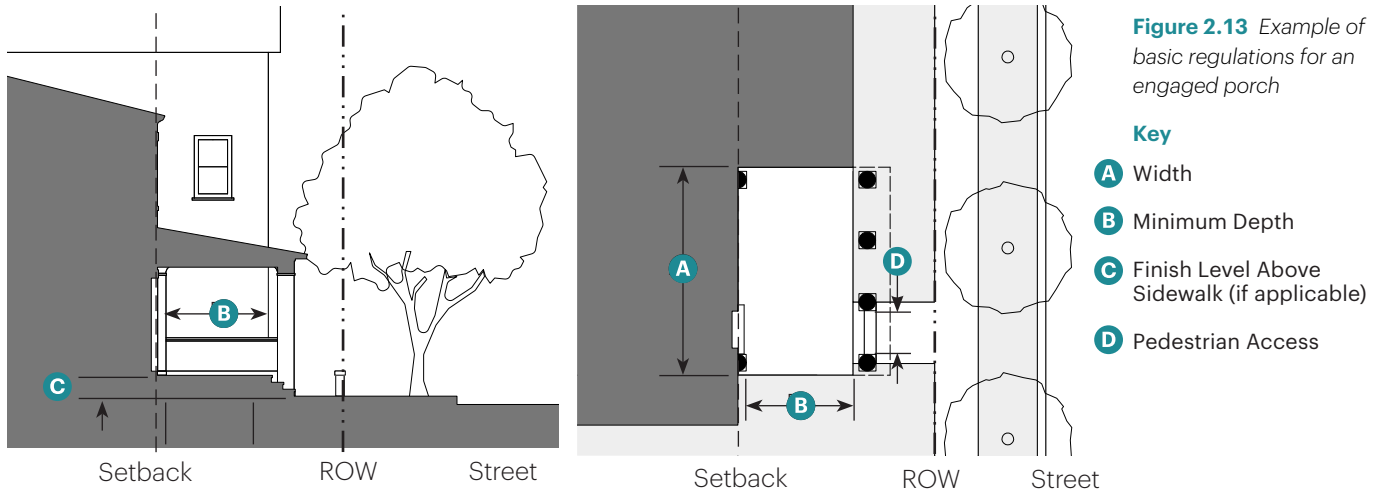

feel of neighborhoods where they are located. A strong sense of community is an important benefit that MMH types provide to residents and neighbors, and frontage types play a role in supporting this by providing a strong connection to the pedestrian-oriented streetscape.

Buildings with entries that are not visible from the street can appear anonymous. Creating clear, distinct entryways with room for socializing reinforces the neighborhood character of Missing Middle types and provides for a more convivial and welcoming streetscape.

Source

¹*Form Based Codes: A Guide for Planners, Urban Designers, Municipalities, and Developers*, Dan. Parolek AIA, Karen Parolek, Paul C. Crawford FAICP, Island Press

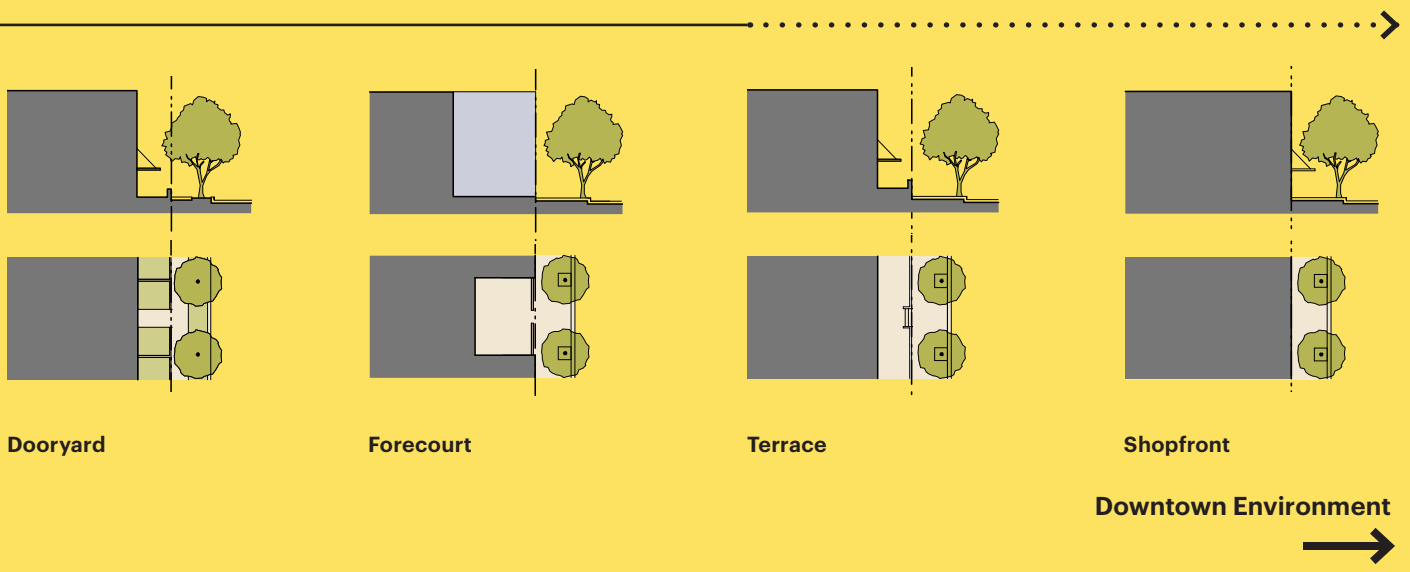

2.4 Missing Middle Housing in the City of Columbia

Columbia, like most historic cities in the country, has existing Missing Middle Housing types in several parts of the city.

Local Examples

Like most cities built before the 1940's, Columbia includes many examples of MMH types. These types are found primarily in neighborhoods adjacent to Downtown. Before the widespread adoption of automobiles, housing needed to be located close to areas where jobs were concentrated, since long commutes were inconvenient or infeasible. In many

US cities, including Columbia, MMH was built nearby commercial and industrial areas so that employees could have access to housing nearby their place of work. Figure 2.14 shows the general location of MMH types in Columbia. Newer examples of multi-family or medium-density housing exist in Columbia outside these areas; however, these examples do

Figure 2.14 Missing Middle Housing in Columbia

Areas where local Missing Middle Housing types exist



not meet the criteria for MMH as identified in Section 2.2.

How Were These Built?

Most of the examples were built before the 1940's when previous regulations allowed them. Newer projects have had to use other zoning tools and processes because, depending on the specific zoning, none are allowed or, a very limited range of the MMH types is allowed.



Duplex Side-by-Side

3131 Lakewood Ave
2 units, resultant density: 9 du/ac
Existing RM-1 zoning would not permit this example to be built today.



Fourplex

1321 Blanding St
4 units, resultant density: 16 du/ac
Existing NAC zoning would permit this example to be built today.



Multiplex Large

2 Gibbes Ct
8 units, resultant density: 59 du/ac
Existing RD zoning would not permit this example to be built today.



Townhouse

1720-1726 Greene St
4 units, resultant density: 12 du/ac
Existing RM-1 zoning would permit this example to be built today.

2.5 Walkable Centers in Columbia

MMH works best in walkable environments, and in turn supports walkability. The analysis identifies existing walkable centers in Columbia.

Walkable Centers

Missing Middle Housing is most successful in areas that are anchored by "Walkable Centers" that provide amenities such as schools, recreation, shopping, services, transit, food and employment. In Columbia, Walkable Centers can be grouped into three categories:

- Downtown
- Neighborhood Main Street
- Neighborhood Center

Each type of center is described and illustrated on the facing page.



Q CLOSER LOOK

What is a Walkable Center?

As discussed earlier, MMH is best suited for areas that are anchored by "Walkable Centers" that provide amenities such as shopping, services, transit, food, and employment. A Walkable Center can be either a group of a couple of parcels (neighborhood center), or as big as a Downtown, or a neighborhood main-street. For MMH to be successful, it needs to be in proximity to vibrant centers that can deliver a variety of amenities, transit, services and entertainment.

Walkable Centers are typically well connected to surrounding areas, making them accessible by multiple modes of transportation. Walkable Centers are the places where communities do things

together. In some cases, they are job centers and in others, places where people from across the city gather to work, shop, learn, play, and celebrate.

Overall, they serve as walkable, bikeable, or "park-once" destinations where community members can meet multiple daily needs in a single trip. When thriving, they are nodes of activity that enliven a neighborhood.

A 1/4 and 1/2 mile radius drawn around the Walkable Center relates to a 5 and 10 minute walking distance from the Walkable Center. These areas are considered especially good locations for Missing Middle Housing.



Columbia Downtown

A citywide destination for retail, food uses, service, entertainment and recreation that includes significant housing and office that use this center as their amenity.



Neighborhood Main Street

A neighborhood destination for retail, food uses, and services that is the most common type of center and amenity for adjacent neighborhoods. Examples of Neighborhood Main Streets are listed below:

- Devine Street
- Rosewood Drive



Neighborhood Center

A Neighborhood Center is a commercial or mixed-use area at the intersection of two important streets that provides convenient services to the surrounding residential neighborhoods in which they are embedded, allowing neighbors to walk or bike there. A Neighborhood Center is smaller and less intense than a Neighborhood Main Street.

Examples of Neighborhood Centers are listed below:

- Five Points
- Columbia College
- University of South Carolina
- VA Campus
- Allen-Benedict
- West Gervais

Where Are Columbia's Walkable Centers?

The map shows existing walkable environments in Columbia focused around a variety of “Walkable Centers” identified through this analysis.

Figure 2.15 Walkable Centers in Columbia

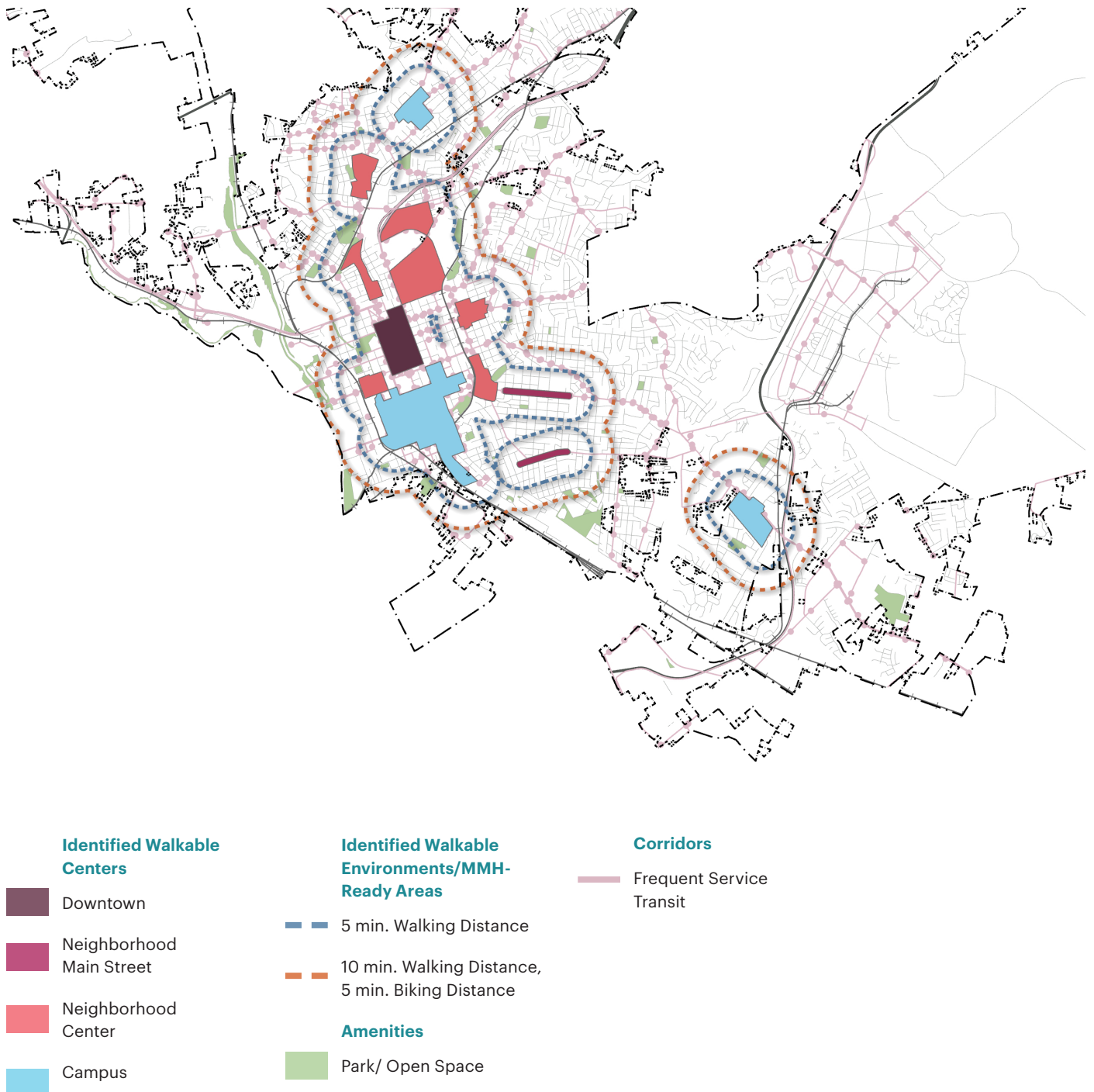

Current Zoning within Walkable Environments

The map shows the zoning districts that are within the Walkable Environments (maximum of ten minute walking distance from the Walkable Centers).

Figure 2.16 Location of Four Zoning Districts Analyzed

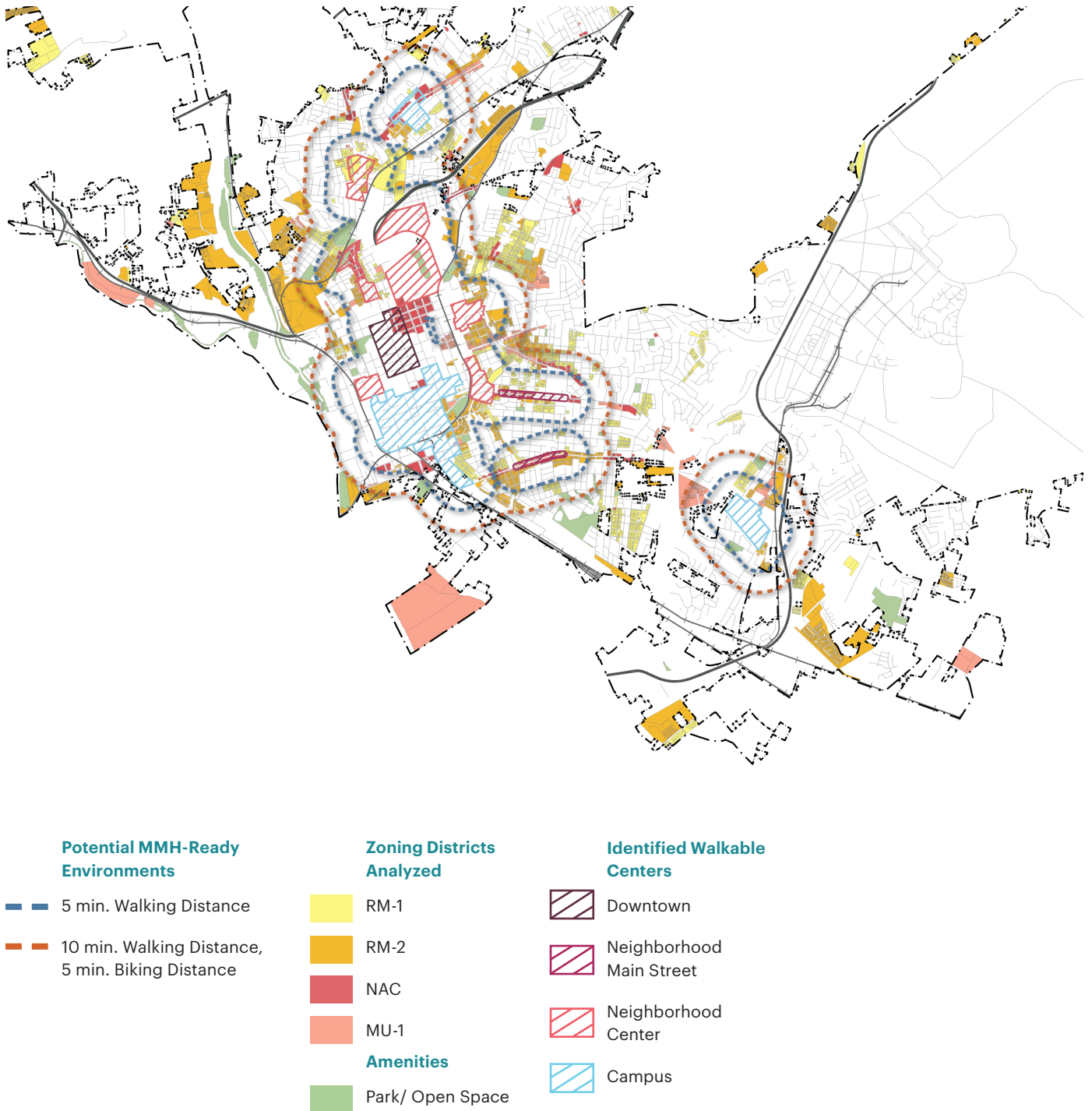

2.6

Missing Middle Housing-Ready Neighborhoods

In addition to mapping existing walkable centers, it is important to also identify places that may not currently be supportive of MMH, but have the potential to do so in the future.

Beyond the Traditional Neighborhood Pattern

Missing Middle Housing types are most successful when located in an existing or newly built walkable context. Buyers and renters of these housing types are looking for walkability and are willing to make trade-offs on other housing features, such as unit size. For most cities, including Columbia, the most walkable neighborhoods are those located near Downtown around the city's historic core.

Missing Middle Housing types can be built in an auto-oriented context, but they will not attract the same kind of buyer or renter, will not deliver more compact, sustainable patterns of development,

and will not achieve the same returns or rents for developers. The higher the walkability of a project context, the smaller the units can be, and the less off-street parking is needed, which can improve the attractiveness of Missing Middle types for developers.

Like most mature cities, Columbia's walkable urban core and traditional neighborhood areas are surrounded by newer neighborhoods characterized by a pattern of development that is more oriented towards automobile use. In many instances, these neighborhoods share many of the same walkable characteristics as the core and traditional neighborhoods to which they are adjacent, but certain

Q CLOSER LOOK

What Does "Walkable" Mean?

For the purpose of this report, walkable describes places where a person can walk or bike to fulfill some or all daily needs. These environments allow for use of automobiles but do not require one for every trip.

Walkable does not mean recreational walking such as on paths and trails, but rather walking to a destination like work, services, a coffee shop, restaurants, bars, entertainment, and other amenities.

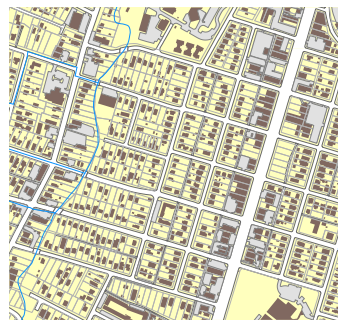

Ideal for MMH

Walkable

Small block lengths, a well-connected street network, and nearby services, shops, and restaurants on a local Main Street support a high degree of walkability for this historic neighborhood.

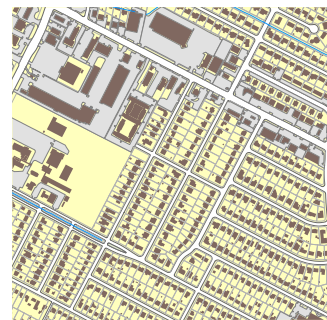

Appropriate for MMH

"MMH-Ready"

A well-connected street network with a mix of block lengths provides a walkable foundation that will support Missing Middle Housing types and enable pedestrian-scale redevelopment of adjacent commercial parcels.

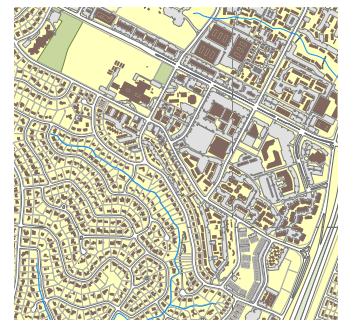

Not Appropriate for MMH

Automobile-Oriented

Minimally-connected streets with frequent cul-de-sacs and commercial areas accessible primarily via higher-speed roadways do not provide a successful environment for Missing Middle Housing.

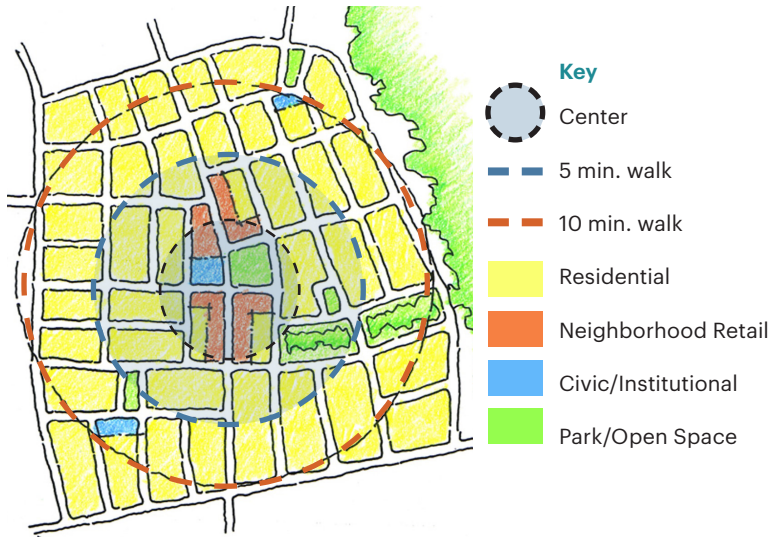

Figure 2.17 Proximity to neighborhood retail, open space, and civic buildings helps to support walkable, MMH-Ready neighborhoods

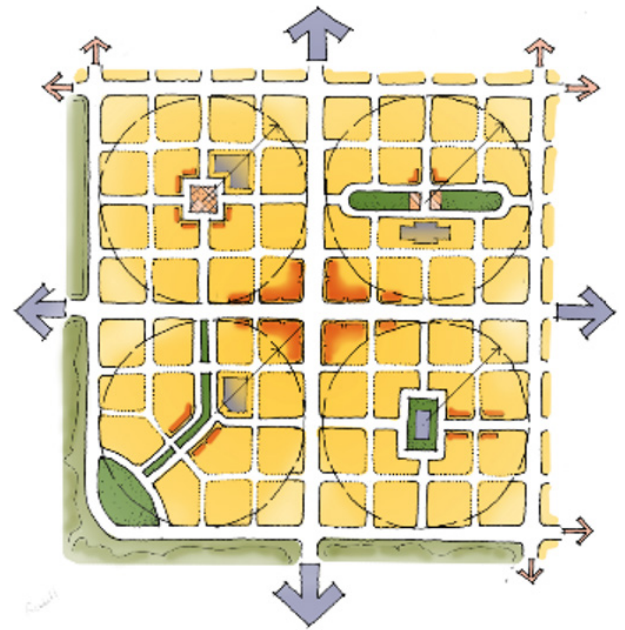

Figure 2.18 How multiple walkable neighborhoods form a walkable environment around the intersection of two major roadways

walkable elements may be missing or may suffer from under-investment. It is these neighborhoods, where incremental changes can improve walkability, that are "Missing Middle Housing-Ready (MMH-Ready)".

What Are the Characteristics of a MMH-Ready Neighborhood?

■ **Smaller block sizes** that allow for better street network connectivity. Smaller block patterns encourage walkability by providing more route choices and reducing the walking distance to get between destinations. In general, dead-end streets, cul-de-sacs, and looping streets diminish an area's walkability, while through-streets tend to increase walkability.

■ **Access to bicycle routes** to provide an alternative to driving for longer-distance destinations. Safe, convenient, and well-connected bicycle facilities provide transportation options for destinations that are too far away for walking.

■ **Accessible to mixed-use areas** that make it possible to satisfy most daily needs — living, working, playing, shopping, dining, worshiping, and socializing — without needing to leave

the neighborhood. While commuting for work, school, and special trips may still require transit or a car, most of the daily needs should be accessible within a ten-minute walk or ½ mile from housing.

■ **Appropriate zoning** that allows for a variety of housing types and encourages compact development to support walkability.

■ **Small to medium lot sizes** that promote house-scale development and disincentivize large tracts of identical housing types, where repetition of building forms leads to a diminished public realm.

Support for MMH-Ready Neighborhoods

To support Missing Middle Housing outside of traditional neighborhoods adjacent to and around Downtown where walkability is high, Columbia should consider making investments in MMH-Ready neighborhoods to make it more convenient for people to walk and bike from their homes to everyday destinations. A combination of infrastructure improvements and new or improved amenities can help to signal that MMH-Ready neighborhoods are available

Q CLOSER LOOK

Examples of MMH-Ready Neighborhoods

- Melrose Heights
- Heathwood
- Shandon
- Rosewood
- Colonial Heights
- Elmwood Park
- Eau Claire

Creating A New Walkable Center for MMH-Ready Neighborhoods

An important component of walkable neighborhoods is a destination to walk to. Walkable Centers provide that destination by creating space for neighborhood-serving retail, services, institutional and public uses in a pedestrian-oriented environment. These places already exist near Columbia's traditional neighborhoods (see Section 2.5, "Walkable Centers in Columbia"), however in areas outside of the city core, the approach to create such places could involve transforming existing commercial centers, like an old mall or

shopping center, or by developing a Walkable Center on undeveloped land.

New or redeveloped Walkable Centers have the potential to transition an area from an auto-oriented pattern of development to a more walkable environment that can transform nearby areas into MMH-Ready neighborhoods.

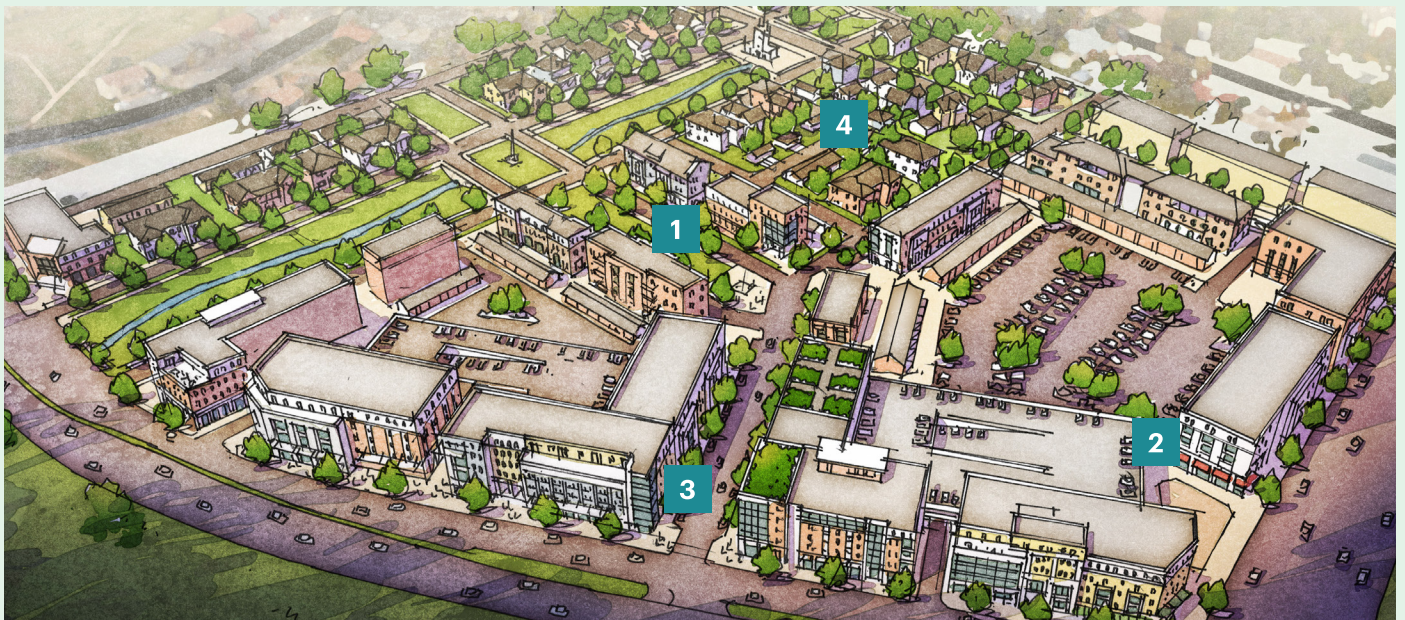

Key Elements of A Walkable Center

An example from Austin, TX shows the transformation of a declining shopping center. While the scale of development in Columbia would likely be different, the following characteristics still apply:

- **Mixed-use** to satisfy the conditions of a vibrant active node that offers a variety of choices, from dining, entertainment, housing and amenities

- **Pedestrian-oriented** and active public spaces to create a more welcoming and safe environment for residents, employees, customers, and visitors.
- **Multi-modal access** that allows people living nearby to access the Walkable Center by biking, walking, or driving.
- **Transition areas** to ensure compatibility with adjacent residential neighborhoods.

Places in Columbia to Consider for New Walkable Centers

- Devine Street at Fort Jackson Boulevard
- Forest Drive
- Two Notch Road
- PrismaHealth-Richland
- Garner's Ferry Road at Veterans Road



Figure 2.19 Redevelopment of this shopping center could result in a new Walkable Center surrounded by Missing Middle neighborhoods



1
Mixed-use center
as the destination



2
Pedestrian-oriented
physical character



3
Multi-modal access



4
House-scale
transitions to adjacent
neighborhoods

One-Size Doesn't Fit All

A Walkable Center is not limited to a certain size. Smaller centers, like a Neighborhood Centers, or a small Neighborhood Main Street can do a lot to support nearby MMH-Ready neighborhoods. These small-scale mixed-use areas can be easily embedded into or developed adjacent to residential neighborhoods to provide convenient services for nearby residents, and help meet multiple daily needs in a single trip made by foot, bike, or car. These

neighborhood-scale Walkable Centers can serve as nodes of local activity that help to enliven a neighborhood and build community.

Smaller block sizes allow for better street network connectivity and encourage walkability by providing more route choices and reducing the walking distance to get between destinations. In general, dead-end streets, cul-de-sacs, and looping streets diminish an area's walkability, while through-streets tend to increase walkability.

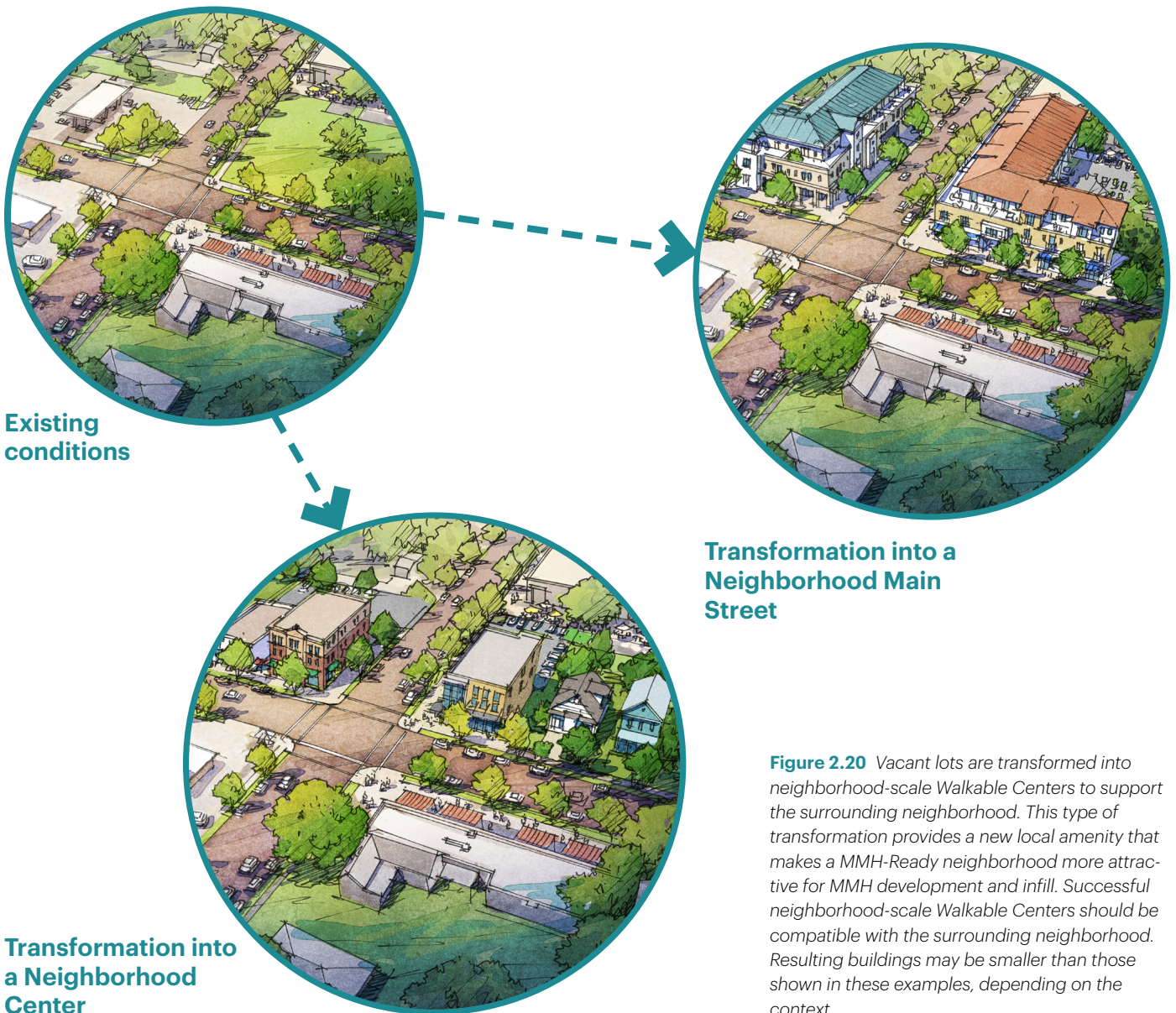
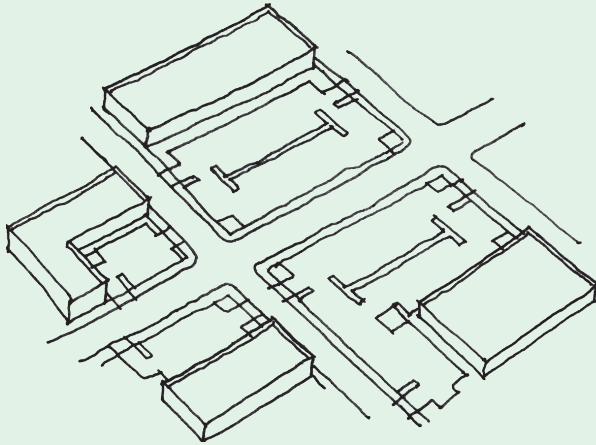

Figure 2.20 Vacant lots are transformed into neighborhood-scale Walkable Centers to support the surrounding neighborhood. This type of transformation provides a new local amenity that makes a MMH-Ready neighborhood more attractive for MMH development and infill. Successful neighborhood-scale Walkable Centers should be compatible with the surrounding neighborhood. Resulting buildings may be smaller than those shown in these examples, depending on the context.

Incremental Change

Small, incremental changes can be just as important in the long run as big, transformative change. The following incremental changes can lay the groundwork for a Walkable Center that can transform surrounding neighborhoods into MMH-Ready Neighborhoods and create suitable environments for Missing Middle Housing.



Existing Conditions

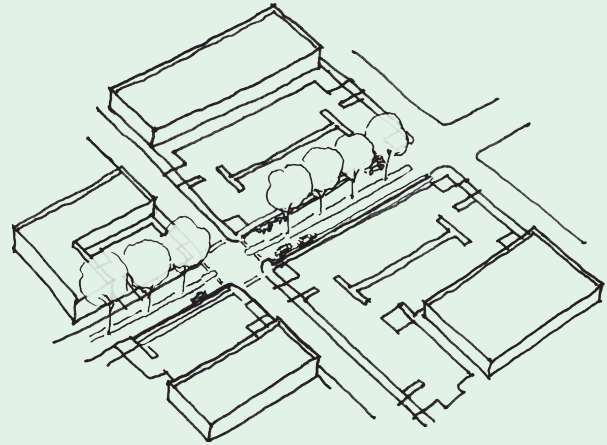

Step 1

Small changes could include landscaping, streetscape improvements and shared roads for bikes and cars.

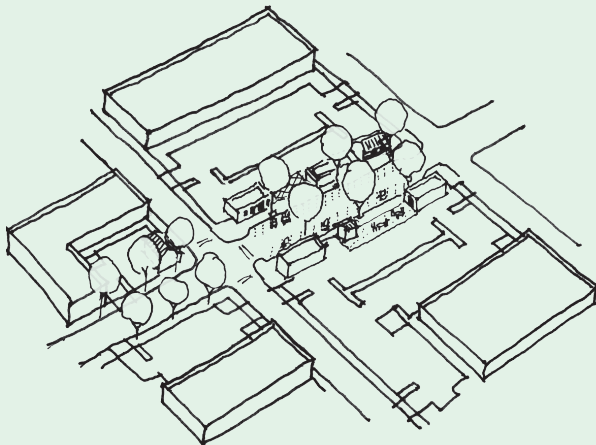

Step 2

Temporary spaces for businesses at the sidewalk edge can help form a center of activity. These small changes can be made where buildings and lots are privately owned and where major changes in near term are unlikely.

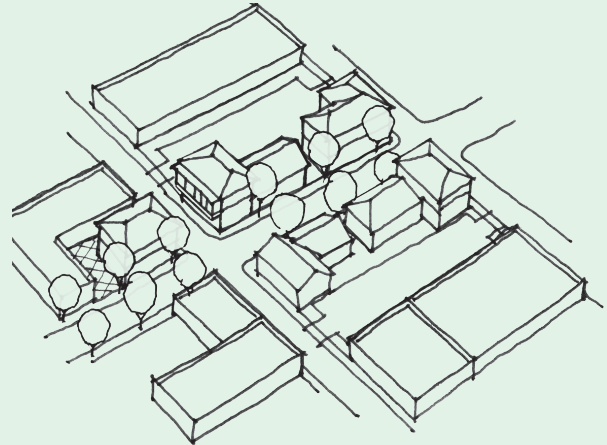

Step 3

Bigger changes may include infill, new development at the sidewalk edge or around public space in areas where there is a desire for development of a more urban character and new buildings.

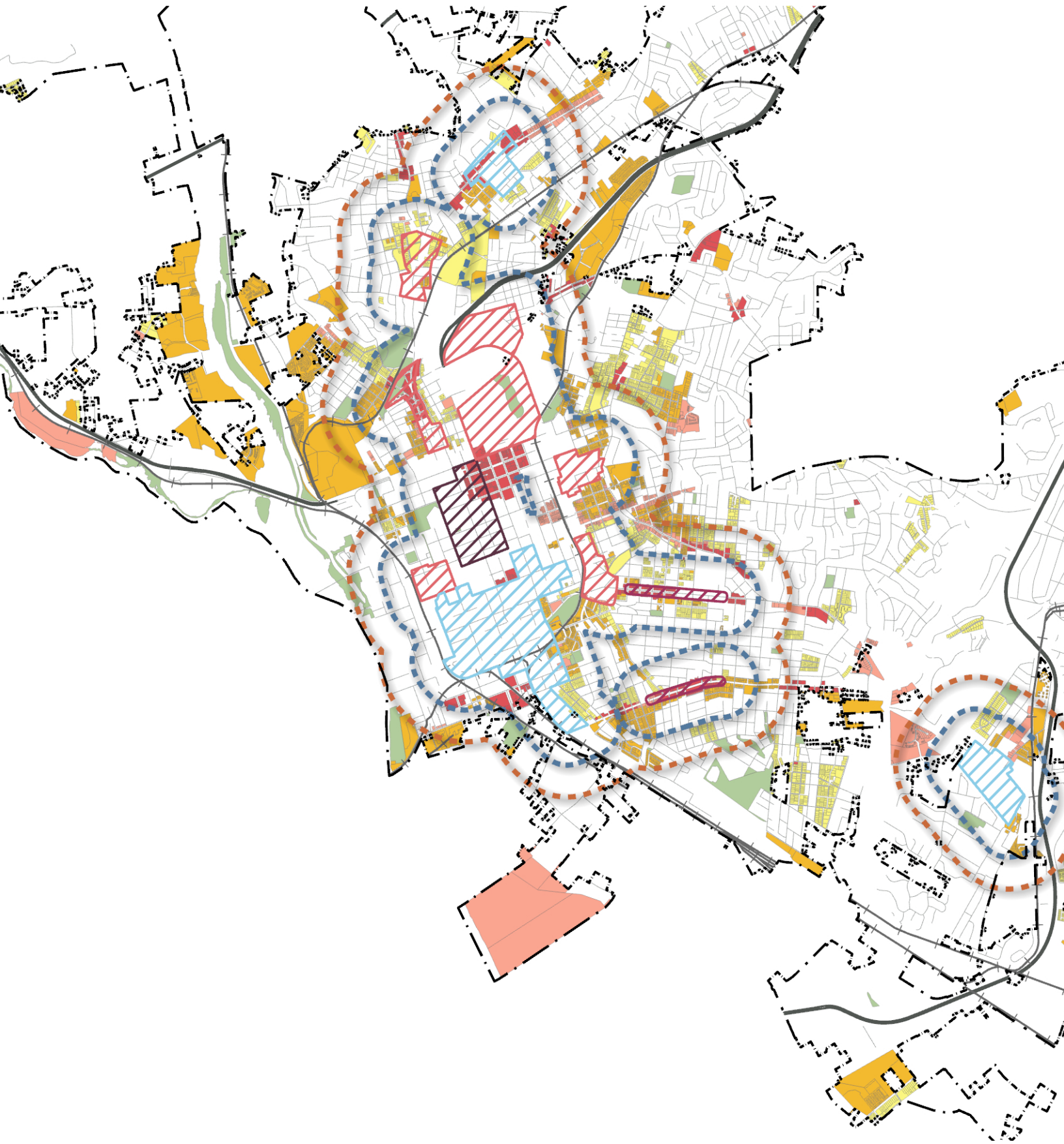



Analysis of Barriers

CHAPTER

3

In this chapter

Summary of Comprehensive Plan and Other Policy Plans	50
Summary of Zoning Districts, Overlays, and Zoning Standards	56
Summary of Barriers	60
Allowed Density	62
Minimum Lot Area/Width	64
Next Steps	66

3.1 Summary of Comprehensive Plan and Other Policy Plans

The following analysis identifies which MMH types are encouraged or enabled by current City policy.

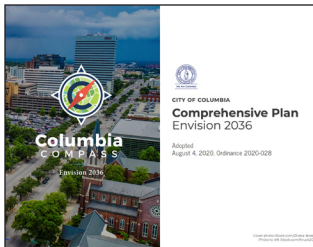

Figure 3.1

*City of Columbia
Comprehensive Plan:
Envision 2036*

City of Columbia Comprehensive Plan: Envision 2036

Envision 2036 expresses the community vision through the Future Land Use Map (Figure 3.2), which shows how different Development Types are intended for different areas of Columbia. Each Development Type is characterized according to the various Building Types and associated Land Uses that form Primary, Secondary, and Tertiary components of the overall Development Type. Those relevant to Missing Middle Housing (MMH) are listed and summarized below.

Building Types/Land Uses

The following Building Types/Land Uses roughly correspond to MMH types:

- **Single-Family Attached (Townhouses).** This is a standard expression of the townhouse as a building type. From the definition, it is unclear whether live/work units would be included in this category.
- **Two-Family (Duplex or Double).** Defining the duplex as two units "under one roof and on one lot" encompasses certain expressions of the duplex type, but does not account for side-by-side duplexes in which the units occupy adjoining lots (sometimes called "semi-detached"). Since townhouses are defined as "three or more" units in a single structure, semi-detached dwellings are passed over.
- **Three-Family.** This describes the building type referred to elsewhere as a "triplex."

- **Multi-Family Small.** This type is described as a structure "accommodating housing units for more than four households," ranging from two to four stories with up to eight units total. This type most closely aligns with the range of house-scale, multi-unit building types that exemplify MMH. Four stories are not necessary to achieve the listed unit count and could lead to buildings that are out of scale with the neighborhood context. In the definition, "units for more than four households" is problematic in that it seems to exclude fourplexes; "four or more" would be more appropriate—unless "four-family dwellings" were to be included as a separate category.

- **Multi-Family Medium.** This category potentially encompasses the more intense MMH types, such as courtyard apartments, with up to twelve units. This number of units can easily be accommodated in three stories or less, as opposed to the six that the building type allows for.

Development Types

Most Development Types include one or more of the aforementioned Building Types/Land Uses as Primary, Secondary, and/or Tertiary components, meaning that Envision 2036 broadly encourages MMH. Significantly, none of the residential Development Types is limited to single-family dwellings. The following

Development Types accommodate one or more MMH types:

- Urban Core Mixed Residential Type 1
- Urban Core Mixed Residential Type 2
- Urban Core Mixed Residential Type 3
- Urban Edge Mixed Residential
- Urban Core Multi-Family
- Urban Edge Multi-Family
- Urban Core Residential Small Lot
- Urban Core Residential Large Lot
- Urban Edge Residential Small Lot
- Urban Edge Residential Large Lot
- Urban Core Neighborhood Activity Center
- Urban Core Community Activity Center
- Urban Core Regional Activity Center

- Urban Edge Community Activity Center
- Urban Edge Regional Activity Center
- Neighborhood Activity Corridor
- Community Activity Corridor
- Regional Activity Corridor
- Employment Campus
- Sports/Amusement
- Central Business Area
- Fort Jackson

Overall, this policy approach is highly favorable to MMH, as it gives clear direction as to where specific MMH types are meant to be enabled. Regulatory updates and rezoning decisions to support MMH can be effectively calibrated on this basis.

Figure 3.2

Future Land Use Map (Source: City of Columbia)

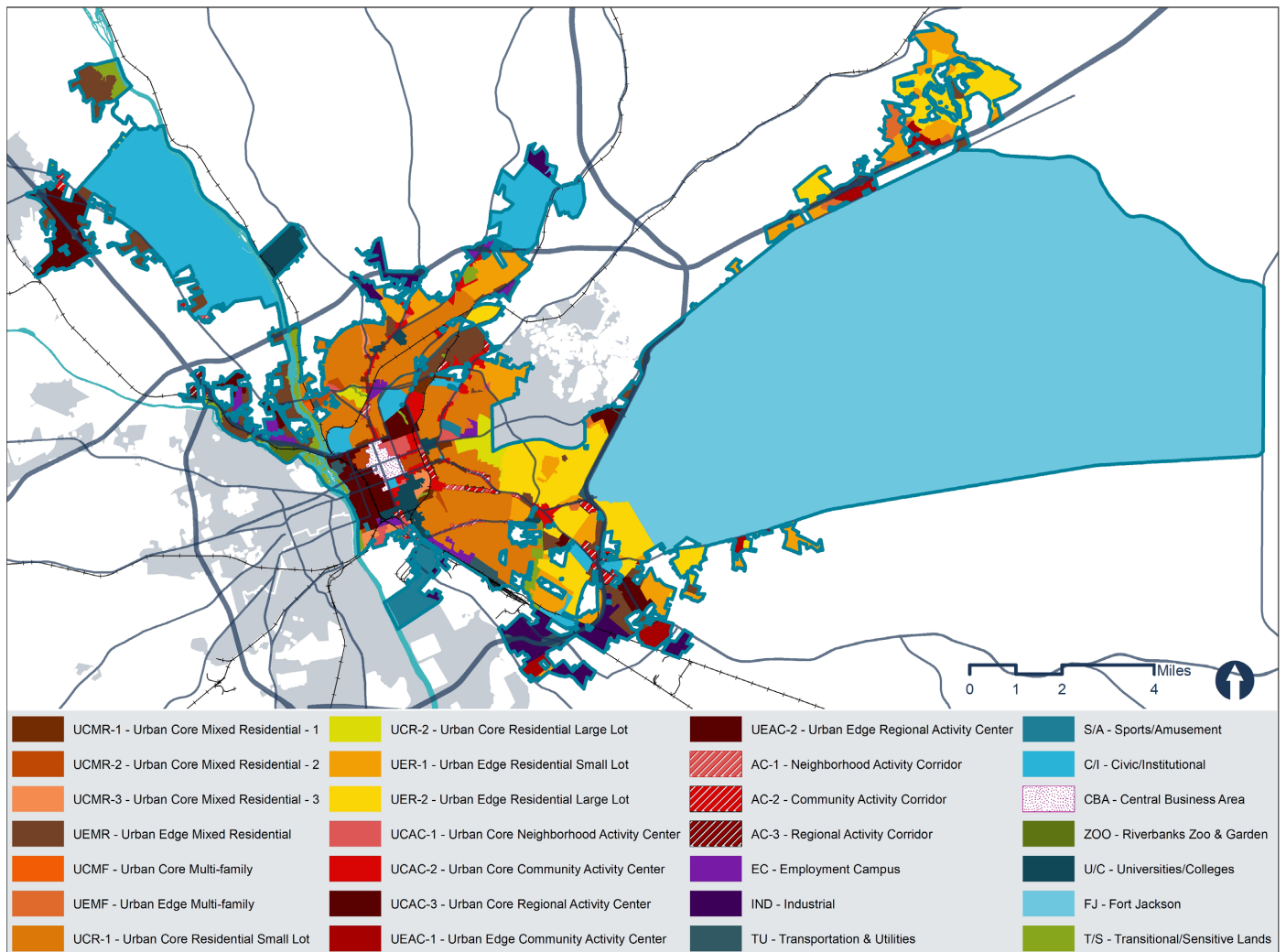

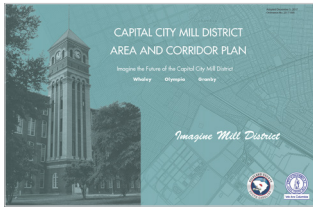

Figure 3.4

Capital City Mill District Area and Corridor Plan

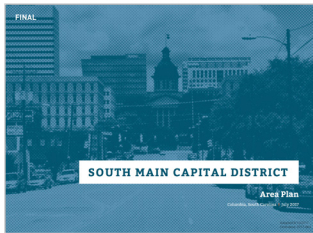

Figure 3.5

South Main Capital District Area Plan



Figure 3.6

West Gervais District Plan

Other Policy Plans

The City's Comprehensive Plan is focused on communities that have organized and prepared an area or master plan. This enables these communities to refine the policy direction for their specific needs and issues. Each community or area plan includes policy direction for stabilizing and/or improving the housing stock, beautification, infrastructure improvements, pedestrian safety, crime prevention, and recreation. The degree to which each plan specifies this direction differs according to each area's needs and priorities. With regard to housing, the following summary is provided for each plan:

Area Plans

South Main Capital District Area Plan (Adopted 2017)

This plan addresses the past, present, and future of the South Main Capital district in downtown Columbia. This plan is developed in concurrence with the update to the future land use chapter in the Comprehensive Plan and The University of South Carolina's efforts to identify future investment sources to fund improvements to the South Main District. Many of the goals of this plan propose public realm improvements which would improve the walkability of this area. These recommendations reinforce walkable environments, which support and are in turn reinforced by MMH.

Another goal of this plan is to increase supply of residential units. In regards to housing, the Master Plan for this area shows large block-scale buildings and recommends setting the height limit range from two to six stories. Most MMH types are house-scale buildings between two to three. The environment this area plan is recommending may be too intense for MMH.

West Gervais District Plan (Adopted 2017)

This plan is intended to provide land use guidance for both public and private development, with the goal of maintaining its economic and cultural position. This plan also proposes bikeways and pedestrian improvements and public realm plans. A building height overlay is proposed as part of the land use recommendations to govern the outcomes of building heights along certain streets within the district. In regards to housing, this plan recommends large multi-family and mixed-use buildings. This area may not be ideal for MMH.

Neighborhood Plans

The Bull Street Neighborhood Plan (Adopted 2012)

The Bull Street Neighborhood Plan is a catalyst to regenerate the existing abandoned state hospital campus. There will be a formed-based code consisting of T-4, T-5, and Special District transect zones. Regarding housing, the Master Plan outlines specific strategies that enable MMH. It strives to promote a mixed-use, pedestrian-scale environment that promotes walkability and multimodal transit options. The T-4 transect zone provides the perfect environment for MMH.

Corridor Plans

Capital City Mill District Area and Corridor Plan (Adopted 2017)

The recommendations in this plan provide guidance on topics like transit, traffic, and connectivity within the Mill District. This plan also recommends the implementation of placemaking policies and improving environmental stewardship. Regarding housing, this document discusses the need for more attainable housing and adding diversity of housing choices to the area. Also,

this plan mentions the Future Land Use classifications for this area are Urban Core Mixed Residential (UCMR-3), Urban Core Neighborhood Activity Center (UCAC-1), and Community Activity Corridor (AC-2). Urban Core Mixed Residential neighborhoods are primarily low-scale, residential buildings but duplexes, triplexes, and small multi-family buildings are allowed in this areas as well. Urban Core Neighborhood Activity Centers also allow small multi-family and single-family attached. Community Activity Corridors also allow multi-family small and medium. Due to the existence of MMH types in the Mill District already and the future land use designations, this area could develop into a great Missing Middle Neighborhood.

Rosewood Corridor and Neighborhood Plan (Adopted 2012)

This plan will guide the future growth and development of the Rosewood corridor and neighborhood. It is important to note that this document builds upon the City of Columbia's Comprehensive Plan that was adopted in 2008. Regarding housing, this neighborhood is primarily single-family houses but there are existing MMH types in the area such as duplexes, triplexes, and multi-unit buildings. However, some of the neighborhood's physical development goals listed in this document are barriers to MMH. One of the goals is to encourage and maintain the single-family heritage of the community and to maintain its "single-family destiny". Both of these goals work against the possibility of MMH being part of a new development strategy for this neighborhood.

Devine Street-Fort Jackson Boulevard Commercial Node Plan (Adopted 2014)

This document gives a detailed vision for this commercial node and provides policy direction to guide investment and growth in this area. This plan addresses key opportunities regarding land use, transportation, urban design and placemaking. It also provides guidance

for future land use and infrastructure decisions to support development and redevelopment. On the topic of housing, in the Land Use section of this plan, townhomes are recommended close to existing single-family neighborhoods. Multi-family types such as condominiums and apartments are recommended in close proximity to transportation corridors. Other Missing Middle types could work well in these areas.

Redevelopment Plans

A Plan for the Redevelopment of East Central City (Adopted 2004)

This plan details the implementation of a redevelopment area in the East Central City where the focus is to create affordable housing. This plan considers 1,050 acres bounded by Harden St (west) Belt Line (north) Forest Acres Community (east) and Santee Ave (south) encompassing twelve neighborhoods. In regards to housing, the infill development in this plans seems focused on single-family development. However, the Master Plan outlines specific strategies that could potentially enable MMH. The location is part of one of the potential Walkable Centers. It is also located in a district with existing schools that could generate a walkable environment. The Master Plan identifies important activity nodes that promote walkability.

Lower Waverly Catalyst Redevelopment Program (Adopted 2006)

The purpose of this plan is to identify blighted and conservation areas within certain portions of the Lower Waverly community. The main objective of this redevelopment plan is to highlight sections of the community that would benefit from privately and publicly funded investment. Regarding housing, this plan mentions the desire for providing a variety of housing options within the existing neighborhood that would accommodate a variety of income levels. MMH could

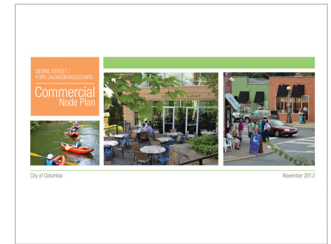

Figure 3.7

Devine Street-Fort Jackson Boulevard Commercial Node Plan

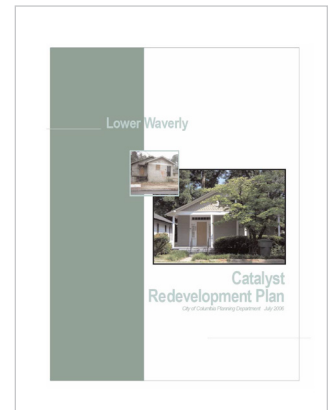

Figure 3.8

Lower Waverly Catalyst Redevelopment Program

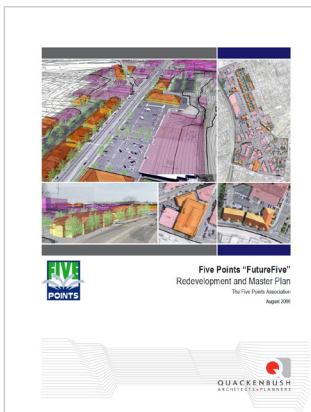

Figure 3.9

Future Five: Five Points Master Plan

provide more attainable units and more housing options for this neighborhood.

Master Plans

City Center Master Plan (Adopted 1999)

The purpose of this Master Plan is to guide current and future investment in the City Center. The study area for the project contains a variety of important institutions including the South Carolina State Capitol and the historic core of the University of South Carolina. This plan has a few recommendations regarding housing. The first recommendation is that the city develop a residential and housing development strategy to encourage housing construction. The second recommendation is to create and reinforce residential neighborhoods. It also provides a vision of the residential nature of certain neighborhoods.

Columbia Owens Master Plan (Adopted 2002)

The purpose of this plan is to outline an investment strategy for public infrastructure and other improvements needed to stimulate economic development in the Rosewood community. The study area is the

commercial/light industrial corridor south of Rosewood Drive along Superior Street, South Edisto Avenue, and Commerce Drive to the Columbia Owens Downtown Airport. This plan is primarily focused on infrastructure. However, these infrastructure improvement promote a walkable environment which is ideal for MMH. Also, it mentions multi-family housing would be appropriate in certain areas and lists townhouse and live/work units as well.

Future Five: Five Points Master Plan (Adopted 2006)

This document provides a strategy for the redevelopment of Five Points. Its main goals are to preserve the unique identity of Five Points, enhance market vitality, promote mixed-use, elevate building character, increase density, and foster diversity. On the topic of housing, the goal to increase density is the most relevant. This plan encourages more multi-story construction, ranging from two to three stories within Five Points. In the Master Plan, it mentions the integration of townhouses and mixed density residential. MMH types would be ideal for the areas designated mixed-density residential.

Figure 3.10

An example of a townhouse in Columbia.



Innovista Master Plan (Adopted 2007)

The goal of this Master Plan is to create a vibrant mixed-use urban neighborhood in Columbia. It recommends extending the historic street grid; constructing mixed-use housing, office space, research facilities, and retail space; and increasing connections between the downtown and the nearby Congaree River. Regarding housing, this plan recommends the creation of an intense residential environment with respect to density and built form. This plan assumes an FAR of 2.0. MMH would be unlikely to achieve this desired intensity.

Master Plan for the Villages of North Columbia (Adopted 2005)

This Master Plan identifies a vision for the preservation and redevelopment within the Villages of North Columbia. Within the project area are many universities such as Columbia College, Lutheran Seminary, and South University. This Master Plan mentions a medium density residential zone, within which townhouses, duplexes, and live/work units are proposed. This suggests that in this zone there may be potential for more building types that are not specifically mentioned. Due to the house scale character of MMH types, they would integrate well into existing single-family neighborhoods.

Crane Creek and North Main Areas Pedestrian Master Plan (Adopted 2017)

This document is the pedestrian Master Plan for Crane Creek and North Main areas. This plan is silent on issues of housing and housing specifics, but it recommends infrastructure improvements that would increase walkability in these areas.



Figure 3.11

Innovista Master Plan



Figure 3.12

Crane Creek & North Main Areas Pedestrian Master Plan

3.2 Summary of Zoning Districts, Overlays, and Zoning Standards

The following analysis identifies which MMH types are enabled by the current City of Columbia Unified Development Ordinance.



Figure 3.13

The palette of MMH Types ranges from buildings with 2 units to courtyard buildings with up to 20 units and represents a resultant density range of 8 to 64 du/ac.

Zoning Districts (Zones)

The following analysis focuses on the four zoning districts that allow housing. The analysis identifies which MMH types are enabled in each district in reference to permitted uses, lot size, and density. Other regulations that pertain to MMH are analyzed in the Zoning Standards section. This analysis assumes that “multi-family dwelling” could refer to MMH types (e.g. cottage courts, fourplexes, small and large multiplexes, or courtyard buildings, depending on the district). This analysis also assumes that “upper-story residential” could include live/work depending on the zoning district.

RM-1

This zoning district permits cottage neighborhood development, multi-family, townhouse, and two-family buildings. Live/work is permitted as a conditional use. The lot size can accommodate a townhouse, duplex, fourplex, multiplex small, and live/work. However, the allowed density (8.7 du/ac) is too low to allow these MMH types to be built.

RM-2

This zoning district permits cottage neighborhood development, multi-family, townhouse, and two-family buildings. Live/work is permitted as a conditional use. The lot size is smaller than RM-1 but can still accommodate MMH. The allowed density (17.2 du/ac) poses a barrier to many MMH types.

NAC

This zoning district permits multi-family, townhouse, and two-family buildings. Live/work is permitted as a conditional use. This zone does not have a density requirement so this is not a barrier to MMH. For multi-family, which the city defines as a building with three or more units, the minimum lot size is 75 feet. This lot width is perfect for the multiplex large and the courtyard building and can accommodate other MMH type such as a fourplex and multiplex small. Lot size is a minor barrier because it does not totally disable MMH from being built, but it limits MMH development on smaller lots within this zone. Larger lots within the NAC district may require additional development standards in order to produce more predictable built outcomes.

MU-1

This zoning district permits cottage neighborhood development, multi-family, townhouse, and two-family buildings. Live/work is permitted as a conditional use. No density limit applies to this zone. The lot size requirements are not a barrier for townhouses and duplexes. In order to enable live/work to be built in this zone, we recommend applying the townhouse lot size requirements to the live/work building type. For multi-family, the minimum lot size is 75 feet. This lot width can accommodate the multiplex large and the courtyard building. However, it prevents smaller MMH typologies, such as the fourplex and multiplex small, from being built on smaller

lots. Lot size is a minor barrier because it does not totally disable MMH from being built, but it limits MMH development on smaller lots within this zone. Larger lots within this zone may require additional development standards in order to produce more predictable built outcomes.

Overlay Districts

Five Points Design Overlay District

The purpose of this overlay is to promote more walkable, mixed-use destinations for more high-density, mixed-use development and pedestrian-oriented community form to preserve the unique village atmosphere of Five Points. The allowance of a maximum building height of 50-75 feet suggests higher-density development. The ground floor use can be commercial, public, civic or institutional, which enables more walkable environments. This overlay highlights the importance of active facades and more concentrated parking structures. However there is no mention of multi-family dwellings or MMH.

Innovista Design Overlay District

This overlay promotes a transition from vacant and low-intensity industrial and commercial to the more walkable mixed-use environment of Downtown. Active street-facing façades and streetscape strategies could help the walkable environment. This overlay does mention multi-family regulations around common areas and public space.

North Main Corridor Overlay District

The purpose of this overlay is to promote a transition from a low-intensity commercial development pattern to a walkable mixed-use corridor with multiples modes of travel. The reduction of off-street parking by 20 percent (Sec. 17-5.2(d)(1), Minimum Number of Street Parking Spaces) will promote more walkable environments that can enable MMH. However, the expansion of non-conforming structures containing manufacturing and wholesale uses

might create a barrier for more walkable environments. There is no mention of multi-family dwellings or MMH.

City Center Design Overlay District

The purpose of this overlay is to promote new development and redevelopment that is consistent with the character of Downtown Columbia as a walkable urban environment with an employment and commercial center. This overlay identifies strategies to revitalize the "City Center" such as streetscape improvements, open space framework, and built form guidelines. Within the development principles, housing is a priority. However, there is no mention of Missing Middle Housing or a multi-family dwelling strategy that could be suitable for the walkable environment.

Historic Preservation Overlay District

The purpose of this overlay within 16 historical sub-districts is to prevent the destruction of historic structures while also promoting new uses, building design, and site features. Within this overlay, new uses can be applied to historic buildings. This overlay also offers a 50 percent reduction in off-street parking requirements. There is no minimum front yard setback and a maximum within 90-110 percent of the average front yard for properties on the same block.

Development Standards

Lot Size

■ **Townhouse:** The townhouse is described in the Unified Development Ordinance as three or more single-family dwelling units, each with its own outside entrance, which share a common exterior wall and are joined together by fire-resistive party walls extending at least from the lowest floor level to the roof. Triplexes and quadplexes are included in this definition, which is not recommended because triplexes and quadplexes are separate types and require their own

standards. The minimum lot sizes in RM-1, RM-2, and MU-1 are consistent with our recommendations and they do not pose a barrier to MMH. In these zones, the code requires five feet between end units and the side yard and ten feet between end units and any secondary yard. This regulation is not a barrier for MMH. NAC does not list a minimum lot width for the townhouse type. However, it does list a minimum lot area of 5,000 square feet, which is too large for an individual townhouse lot.

■ **Duplexes:** The minimum lot area of 5,000 square feet for duplexes in the RM-1, MU-1, and NAC districts is a reasonable lot size for a duplex, although it is possible for a duplex to be built on a lot smaller than this. The minimum lot area of 3,000 square feet in RM-2 can still accommodate a duplex. Since this requirement regulates the minimum lot area, it does not prevent duplexes from being built on lots that are larger. In RM-1, RM-2, and MU-1, the minimum lot widths range from 40-50 feet; this range is ideal for most duplexes. The NAC district does not list a minimum lot width for duplexes.

■ **Multi-family:** Multi-family is described in the Unified Development Ordinance as a building containing three or more dwelling units. The minimum lot area is 5,000 for multi-family in RM-1. This lot area can accommodate duplexes, fourplexes, and multiplex small. The minimum lot area of 3,000 square feet in RM-2 is smaller than required for most MMH types. Since this requirement regulates the minimum lot area, it does not prevent multi-family buildings from being built on lots that are larger. The minimum lot area is 10,000 square feet for multi-family in MU-1 and NAC districts. This enables larger MMH types such as the cottage court, multiplex large, and courtyard buildings, but is too large for some of the smaller types. The minimum lot widths for multi-family dwellings are 50 feet and 40 feet in the RM-1 and RM-2. These minimum lot widths are ideal for

duplexes, fourplexes, and multiplex small. The minimum lot width of 75 feet in MU-1 and NAC accommodates the larger MMH types such as cottage courts, multiplex large, and courtyard buildings. However, this minimum lot size prevents other MMH types from being built on smaller lots in these zones.

■ **Live/work:** In the Unified Development Ordinance, live/work is defined as a building or portion of a building combining a dwelling unit with an integrated work space principally used by one or more of the dwelling unit residents. Columbia's current standards are ambiguous regarding which set of standards for minimum lot size apply to live/work. We would recommend applying existing townhouse development standards to the live/work building type as required.

Parking

The existing parking requirements are too high for successful MMH in the RM-1 and RM-2 Zones. Townhouses require a minimum of 2 spaces per unit, multi-family dwellings require 1.75 spaces per unit. All other housing types require 2 spaces per unit. Mixed-use buildings determine the required number of off street parking spaces in accordance with an approved alternative parking plan. The NAC and MU-1 districts do not have minimum parking requirements. The Five Points Design Overlay District (OV-5P) offers a reduction in off-street parking of 20 percent. For the Historic Preservation Overlay District, the minimum off-street parking is 50 percent of the requirements established. Overall, lower parking ratios are advantageous for smaller-sized units for reasons of attainability and feasibility. In some cases, there may be potential adverse effects that can be addressed through policies such as local resident parking permits.

Setbacks

MMH typically functions with a 10-15 foot front setback, a 15-20 foot rear setback, a 5-10 foot interior side setback, and a

10-12 foot side street setback. In all four zones under consideration, the setback requirements enable MMH. The City Center Design Overlay and the Historic Preservation Overlay have no minimum required front yard setback.

Buffer Yards

The buffer transition yard poses a barrier to MMH. The City of Columbia defines a buffer transition yard as a "landscaped transitional area intended to separate and screen adjacent buildings of differing uses". A multi-family building containing three to ten units is considered medium impact residential and requires a 20 foot buffer transition yard if it is located next to a lot zoned for single-family. A multi-family building, containing ten to 20 units, is considered high-impact residential and requires 30 feet in the same adjacency condition. By requiring buffer yards depending on adjacencies, the result can unintentionally decrease the buildable area on a lot. Although the UDO allows buffer yard widths to be reduced by half with the construction of a masonry wall, the cost of the wall construction and the size of the remaining buffer yard may still impose barriers to MMH on many existing lots. We recommend that buffer yards not be required for MMH because these building types are house-scaled and are unlikely to present compatibility issues with adjacent single-family homes in terms of size, intensity, or use.

Fire Sprinklers

The International Building Code (IBC) requires fire sprinklers for buildings with three or more units. This requirement can be a barrier to MMH because the cost of including such systems in house-scale MMH buildings is proportionally higher than for larger projects. In South Carolina, fire sprinkler mandates are controlled at the state level, meaning that Columbia's ability to address this barrier is limited. On the other hand, there is potential to offer other incentives for MMH development to counteract the cost burden that would otherwise discourage MMH projects.

Units per Building

The standard MMH townhouse building consists of no more than four units in a row. Although townhouses are permitted in the RM-1, RM-2, MU-1, and NAC districts, the code's definition of townhouse places no upper limit on the number of townhouses that can be combined in a single building. As a result, there is no guarantee that the scale of the resulting buildings will be compatible with that of nearby houses. In a house-scale context, it is recommended to regulate either the number of attached townhouses or the overall building width to ensure compatibility.

Open Space

The open space requirements for residential uses in the RM-1, RM-2, and MU-1 districts are 25 percent of the development site area. This number is quite high, but MMH types can still accommodate this amount of open space per lot. For the NAC district, the open space requirement is 15 percent of the development site area which does not pose a barrier for MMH.

Building Height

MMH typically does not exceed two and a half stories, or about 35 feet overall in height. The RM-1 and MU-1 districts allow a maximum building height of 40 feet which is ideal for MMH. The RM-2 and NAC district allow a maximum height of 50 feet, which can confuse the implementation of MMH and invite speculation about intended form because of the height difference with MMH. We recommend that where there is the possibility of three story buildings, the "Larger MMH" approach should be considered carefully.

Lot Coverage

Maximum lot coverage is 50 percent in RM-1 and RM-2, which can accommodate Missing Middle building types. The MU-1 district only provides lot coverage requirements for townhouses; it requires 50 percent lot coverage, which is not a barrier for MMH. Lot Coverage requirements are not applicable in the NAC district.

3.3

Summary of Barriers

The table below identifies the various types of barriers to MMH within the City's Zoning Code and how and the degree to which the nine MMH types are enabled under the current zoning regulations. This table summarizes and graphically represents the findings from the written analysis in Section 3.2.

Barriers for MMH in the City of Columbia				
Barriers to MMH	RM-1	RM-2	NAC	MU-1
Max. Density	✗	✗	✓ ¹	✓ ¹
Min. Lot Size	✓	✓	●	●
Max. Lot Coverage	✓	✓	✓ ⁴	✓ ⁶
Min. Setbacks	✓	✓	✓	✓
Min. Off-Street Parking	✗	✗	✓ ⁵	✓ ⁵
Buffer Yards Required	✗	✗	✗	✗
Allowed Uses	✓	✓	✓	✓
Min. Open Space	✓	✓	✓	✓
Max. Height	✓	✓	✓	✓
Fire Sprinklers Required for 3 or more units ²	✗	✗	✗	✗
Number of MMH Types Identified	5 ²	5 ²	5 ³	5 ²

Key

- ✗ Major Barrier
- Minor Barrier
- ✓ Enables MMH

Notes:

n/a = Not applicable

¹No density regulation.

²Zone district identifies duplex, townhouses, multi-family, cottage neighborhood, and live/work.

³Zone district identifies duplex, townhouses, multi-family, and live/work.

⁴No lot coverage regulation.

⁵No off street parking regulation.

⁶Lot Coverage only applies to townhouses. Maximum lot coverage is 50 percent of the total site area.

This page intentionally left blank





3.4 Allowed Density

This section discusses allowed density as a key limiting factor, with reference to resultant densities from typical MMH building types.

Allowed Density

Most MMH types are not enabled in the zoning districts reviewed because current density limits are too low. However, simply increasing the maximum allowed density could create other issues such as large buildings that are not contextually appropriate for their neighborhood.

Increasing the maximum allowed density needs to be coordinated with carefully identifying the appropriate MMH building types for Columbia's different areas and then incorporating the resultant density range of those types along with standards for maximum building footprint and lot width.

- Key**
-  Range of MMH Type
 -  Range Enabled by Zoning
 -  MMH Type Enabled
 -  MMH Type Not Enabled



Duplex Side-by-Side
8-22 du/ac



Duplex Stacked
8-29 du/ac

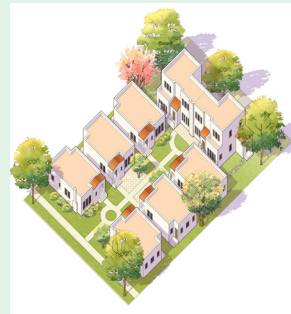

Cottage Court
19-24 du/ac



Fourplex
17-35 du/ac

Zoning and Density Limits:

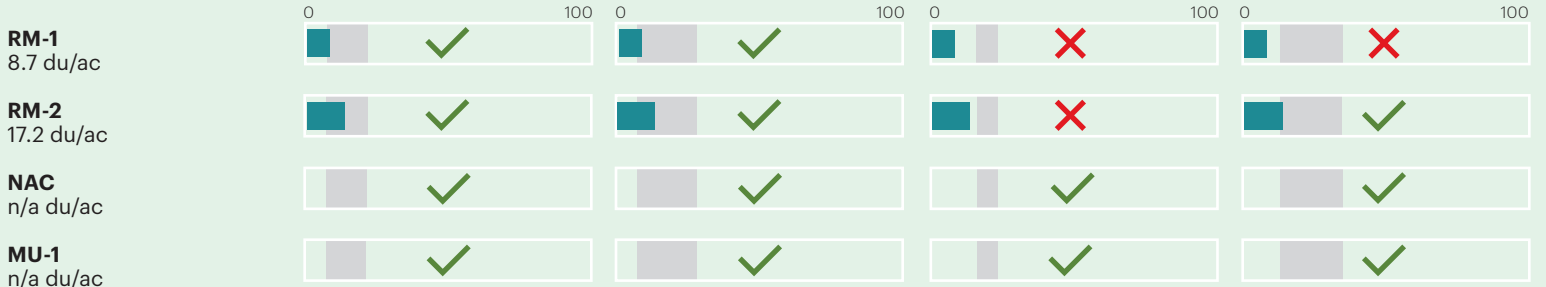

MMH Types Enabled by Current Density Standards

The chart below shows which and how much of each MMH type is enabled in each district based on the maximum allowed density. When the gray area does not contain any green, that MMH type is not enabled.

Depending on the support for changing existing zoning, the MMH types and their standards could be adopted as new zoning or as an overlay that only applies to identified walkable neighborhoods.

The standards could include density standards or they could be silent on density. In either approach, the characteristics of each MMH type need to be publicly discussed and tested for the specific areas where they want to be used.

Recommendations

We recommend either of two approaches:

- Increasing the maximum allowed density for MMH types based on the lot size realities of MMH; or
- Regulate MMH using building types with clear footprint and unit limits instead of density.



Multiplex Small

41-44 du/ac

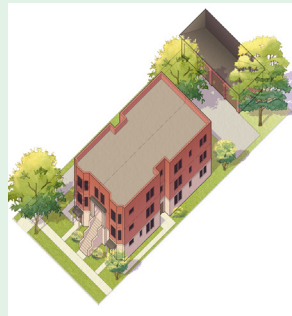

Multiplex Large

44 -48 du/ac



Courtyard Building

28-36 du/ac

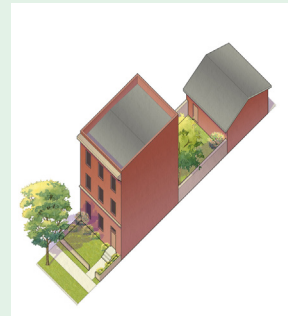

Townhouse

8-32 du/ac

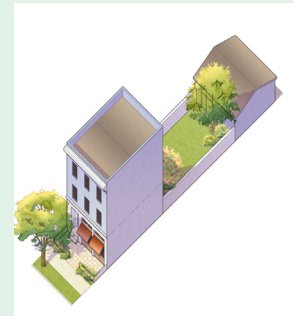

Live/Work

8-32 du/ac

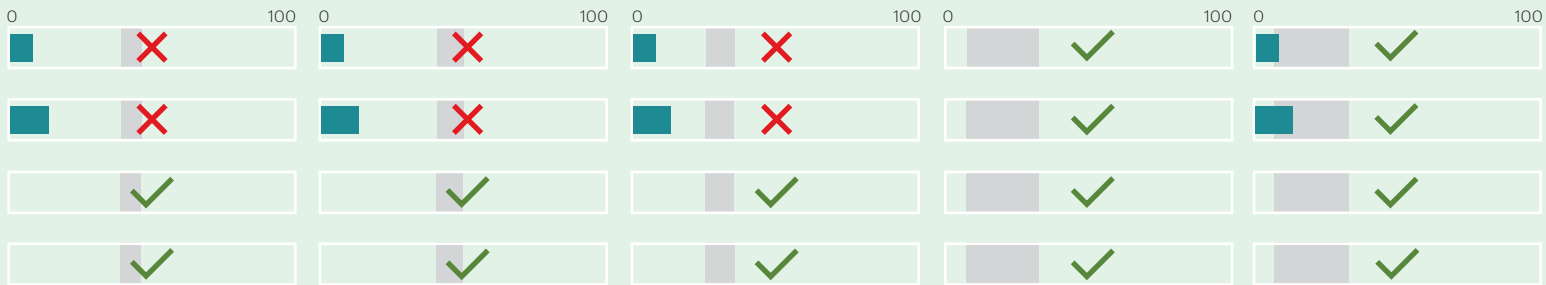

3.5 Minimum Lot Area/Width

This section analyzes how lot width is an important consideration for typical MMH building types.

Importance of Lot Width

The existing zoning standards regulate development by using lot area as a way to reinforce maximum allowed density. This approach may be appropriate for larger projects but not necessarily for infill lots. The approach of regulating using lot area prevents some housing types that are otherwise physically compatible with single-unit dwellings.

Lot width can be a more effective regulation than lot area because many projects can comply with the minimum lot area but still result in a building that is too large for its context. Even with low-density housing types such as a duplex, if allowed to fill up the building envelope, it can result in a building that is within the density limits but is larger than nearby houses in the same neighborhood.

In contrast, regulating by lot width results in standards for maximum building footprints that are coordinated with a variety of lot widths that fit well and make sense in lower-intensity neighborhoods. This enables MMH, increasing housing choices. In Columbia, it is important to note that lot size applies only to newly created lots. Existing recorded lots may be redeveloped, regardless of size, if the use is permitted.

The Palette of Missing Middle Housing Types with Typical Lot Width Ranges

The palette of MMH types is provided for reference to the typical lot width range of each type



Duplex Side-by-Side
40'-75'



Duplex Stacked
30'-75'



Cottage Court
90'-160'



Fourplex
50'-80'

MMH Types Enabled by Current Lot Width Standards

In the table below, the gray bars show the typical lot width range for each MMH type based on front or rear vehicle access. A colored dot

represents the minimum lot size for each zoning district. We recommend that the lot width dimensions be coordinated with the MMH types intended for each zoning district.

Key

Typical MMH Lot Width Range (minimum to maximum)

Minimum Required Lot Widths

- RM-1 (min. lot width)
- RM-2 (min. lot width)
- NAC (min. lot width)
- MU-1 (min. lot width)

¹ Minimum 40 feet for Duplex Side-by-Side

² Reflects the width of a single lot.

³ Reflects the width of a single lot. The lot width represented in this chart apply the townhouse minimum lot width requirements to a live/work building. The MMH live/work type includes ground story residential.

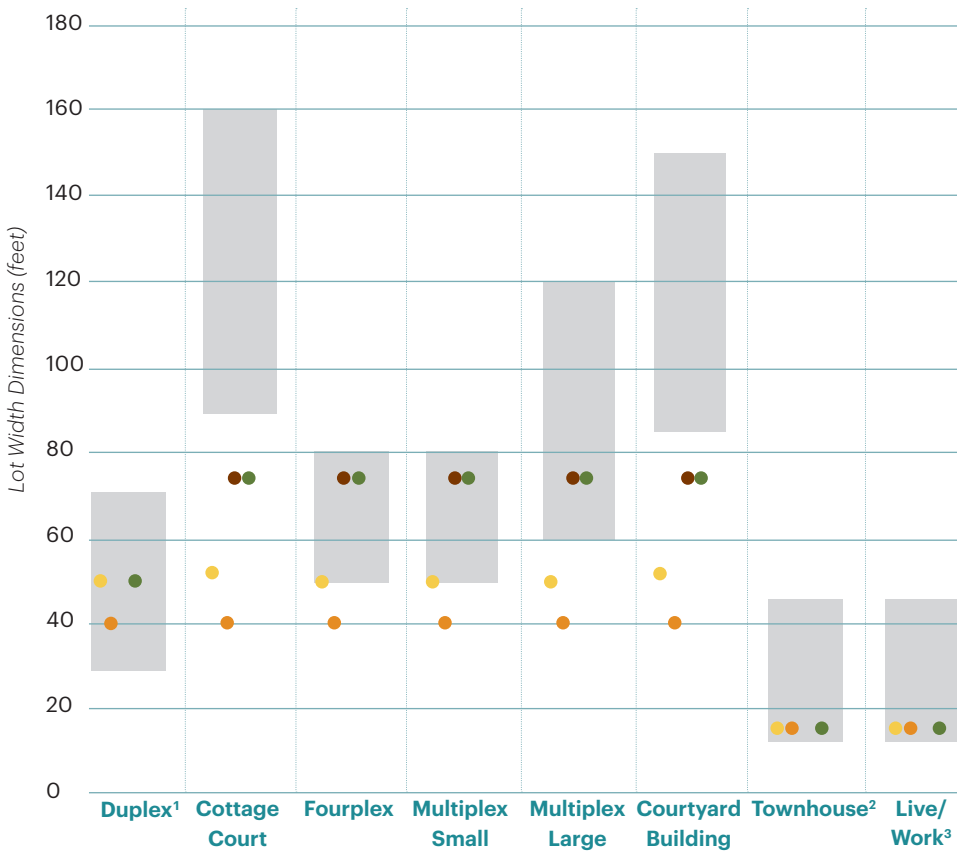

Multiplex Small
50'-80'

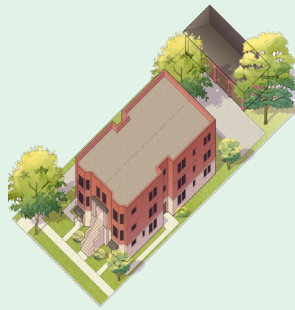

Multiplex Large
60'-120'



Courtyard Building
85'-150'

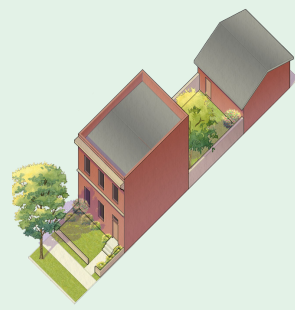

Townhouse
16'-45' (single unit)
56'-158' (3-4 units in a row)



Live/Work
16'-45' (single unit)
56'-158' (3-4 units in a row)

3.6

Next Steps

The findings from the MMH Scan™ will inform the next stage of the project, the MMH Deep Dive™ for Columbia, SC.

Recommendations for Implementing MMH

This MMH Scan™ (Analysis + Definition of Barriers to MMH) is the first of a two-part analysis and focuses on identifying barriers to MMH. The MMH Deep Dive™ (Testing + Solutions for MMH) is a more detailed analysis of the City's zoning and will include the following steps:

■ **Test fits on selected sites** in walkable contexts to identify the number of dwellings allowed and the maximum building size under two scenarios:

- Existing zoning, and

- Existing physical conditions without limitation by existing zoning but within the context of the neighborhood. In other words, what would fit well if it was allowed?

These results are intended to provide further insight about recommended improvements and changes to existing standards.

■ **Recommend changes** to the Policy Plans as well as to zoning standards.

■ **Prioritize the recommendations** to identify those items that need to happen first.

Figure 3.14

An example of townhouse development in Columbia.



Figure 3.15 Zoning Districts within Walkable Environments

